



3501 Kishwaukee Street
P.O. Box 7480
Rockford, IL 61126-7480
815-387-7400
815-387-7538 (FAX)

Rick Pollack, President
John Sweeney, Vice President
Ben Bernsten, Clerk/Treasurer
Don Massier, Trustee
Elmer Jones, Trustee
Timothy S. Hanson, Executive Director

INVITATION TO BID
MANHOLE FRAMES & LIDS MAY 1, 2021 – APRIL 30, 2022
BID #21-204

December 18, 2020

Name of Bidding Firm: _____

Address: _____

City: _____ State: _____ Zip: _____

Phone: _____ Fax: _____

Email: _____

Bid Opening Time and Date: 2:00 P.M., January 8, 2021

Bids will be accepted until the specified opening time and date. Any bid delivered after the opening time and date will be refused.

The Graceffa Administration Building at 3501 Kishwaukee Street is currently closed due to the COVID-19 pandemic. The bid opening for **Manhole Frames & Lids** will be held via Webex at 2:00 P.M. on January 8, 2021. Please use the following information to access the meeting:

Meeting link:

<https://rrwr.webex.com/rrwr/j.php?MTID=m833d9f370b77ae71a3993773c1d30e03>

Meeting number: 146 565 6401

-OR-

Join by phone

+1-408-418-9388 United States Toll

1-844-992-4726 United States Toll Free

Access code: 146 565 6401

Bid Deposit/Bid Bond: NO

Prevailing Wage: NO

Performance Bond: NO

PLEASE MARK THE RETURN SEALED ENVELOPE:

1. Bid Opening Date and Time
2. Title of Job
3. Bid Number

SEND BIDS TO:

Rock River Water Reclamation District
3501 Kishwaukee Street
Rockford, IL 61109

BIDS WILL NOT BE ACCEPTED BY FAX OR EMAIL.

If the Illinois Department of Human Rights registration number has not been obtained, this number must be provided within 5 business days after the date of bid opening.

Bid results are available after contracts are awarded at the Regular Meeting of the Board of Trustees, held on the fourth Monday of the month. Please call 815-387-7425 or visit www.rrwr.dst.il.us

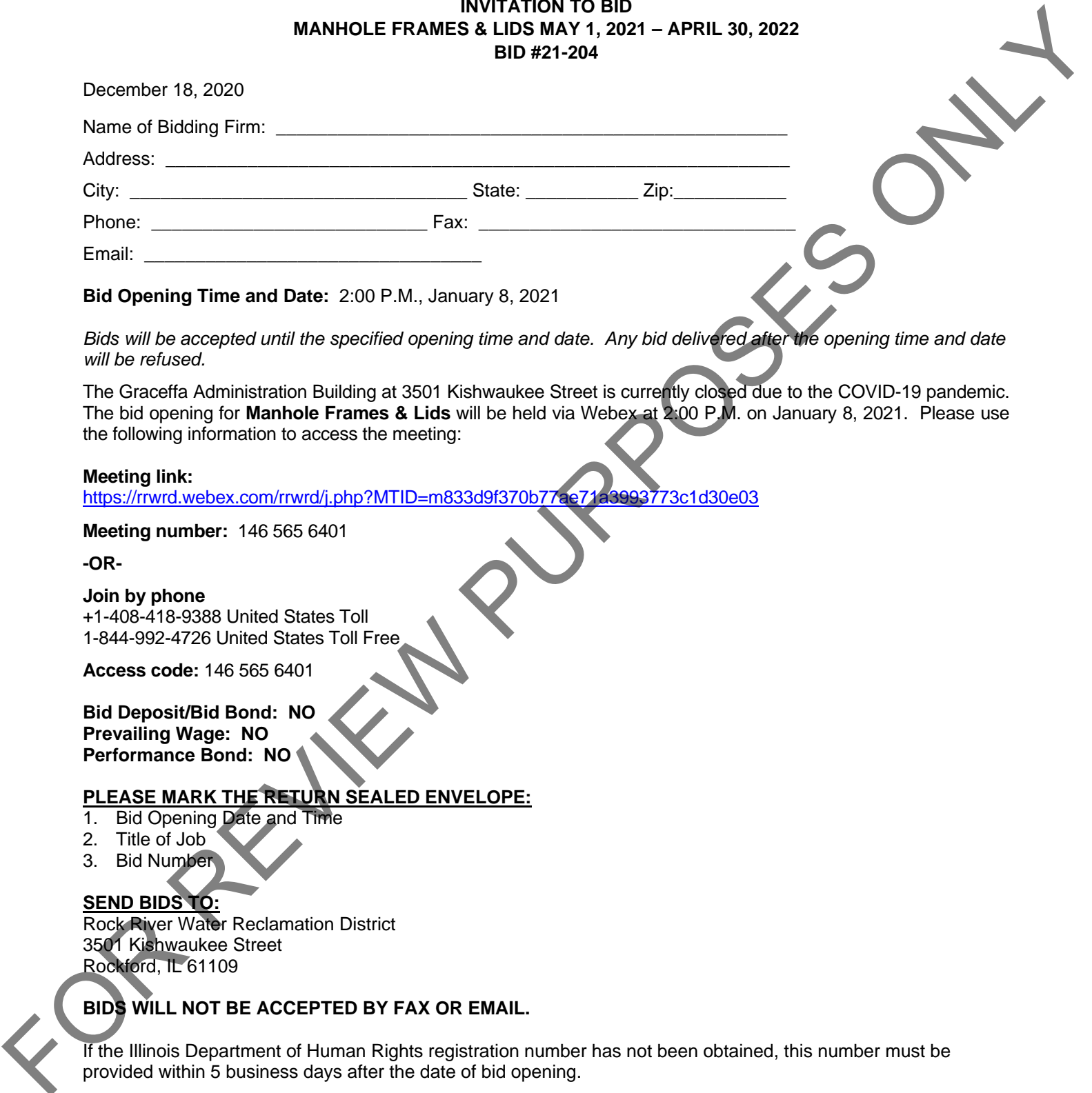

I
**NOTICE
ROCK RIVER WATER RECLAMATION DISTRICT
INVITATION TO BID #21-204
MANHOLE FRAMES & LIDS
MAY 1, 2021 TO APRIL 30, 2022**

The Rock River Water Reclamation District will receive sealed, signed bids for **Manhole Frames & Lids - May 1, 2021 to April 30, 2022** at the District's offices, 3501 Kishwaukee Street, until 2:00 P.M. on January 8, 2021.

The scope of this project involves the purchase of Neenah R-1670 self-sealing, non-rocking manhole frames and lids (or equivalent); Neenah R-1670 self-sealing, non-rocking, heavy-duty lids (or equivalent); Neenah R-1647-A low-profile, self-sealing, non-rocking, heavy-duty frames and lids (or equivalent); Neenah R-1772 self-sealing, heavy-duty lids (or equivalent); Neenah R-1915J self-sealing, heavy-duty frames and lids (or equivalent) with three (3) equidistant bolt holes in flanges on 30" diameter bolt circle for 1/2" anchor bolts; Neenah R-1973-1 riser casing and lid (or equivalent), as specified in the Rock River Water Reclamation District *General Provisions and Technical Specifications for Sanitary Sewer Construction*.

The Graceffa Administration Building at 3501 Kishwaukee Street is currently closed due to the COVID-19 pandemic. The bid opening for **Manhole Frames & Lids** will be held via Webex at 2:00 P.M. on January 8, 2021. Please use the following information to access the meeting:

Meeting link:

<https://rrwr.d.webex.com/rrwr.d/j.php?MTID=m833d9f370b77ae71a3993773c1d30e03>

Meeting number: 146 565 6401

-OR-

Join by phone

+1-408-418-9388 United States Toll

1-844-992-4726 United States Toll Free

Access code: 146 565 6401

No bid shall be withdrawn after the opening of bids without consent of the Rock River Water Reclamation District for a period of 60 days after the scheduled time of receiving bids.

Copies of the Invitation to Bid for review purposes only are available through the Rock River Water Reclamation District web site, www.rrwr.d.dst.il.us. Bid documents for submittal are available by contacting Purchasing at mroach@rrwr.d.illinois.gov or (815) 387-7425.

Request for information related to this bid should be directed to Terry Stoll, Collection Systems Maintenance Division Manager of the Rock River Water Reclamation District, 3501 Kishwaukee Street, P.O. Box 7480, Rockford, IL 61126-7480; telephone 815-387-7588.

The District will confirm any award decision in writing, to the successful bidder.

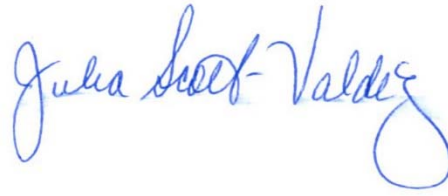

Julia Scott-Valdez
Director of Management Services
Rock River Water Reclamation District

FOR REVIEW PURPOSES ONLY

II

**GENERAL SPECIFICATIONS AND INSTRUCTIONS
INVITATION TO BID**

**MANHOLE FRAMES & LIDS
MAY 1, 2021 TO APRIL 30, 2022**

2.1 Bid Preparation

Where applicable, the bidder shall submit his bid on the forms the District provides in this document. **The bidder shall complete all applicable blanks.** He may submit additional information as he believes necessary on his stationery, under signature of the authorized representative who completes this document's forms.

If this Invitation to Bid contains inconsistencies between sections, Section III - Detailed Specifications shall supersede Section II - General Specifications, which shall supersede Section I - Notice. **No warranty is made or implied as to information contained in these specifications.**

An authorized officer or individual must sign the bid. Authorized signature must be the individual owner of a proprietorship, a general partner of a partnership, or the corporation officer who is authorized to sign for a firm and whose title is affixed.

All prices and notations shall be in ink or typewritten. The bidder may cross out mistakes and type corrections adjacent to the point of error. The person who signs the bid shall initial such corrections, in ink. **If the District finds a bidder's entry to be illegible, it may, at its sole discretion, reject the bid.**

2.2 Submission of Bids

The District **will not** receive bids in electronic format or by facsimile. The bidder shall return his bid in a sealed envelope, clearly marked as "**Bid No. 21-204: Manhole Frames & Lids – May 1, 2021 to April 30, 2022**". **The District can not ensure that the sealed bid will not be prematurely opened if the bidder does not clearly identify his bid envelope.**

Mailing labels should be addressed to:

Rock River Water Reclamation District
P.O. Box 7480
Rockford, IL 61126-7480

Bids sent via package delivery service should be addressed to:

Rock River Water Reclamation District
3501 Kishwaukee Street
Rockford, IL 61109

If the bidder chooses to hand-deliver his bid, he shall deposit it with the Main Entrance Receptionist, 3501 Kishwaukee Street, Rockford, IL 61109 between the hours of 8:00 A.M. and 4:30 P.M.

2.3 Illinois Department of Human Rights Registration Number

All bidders inside and outside of Illinois must provide an Illinois Department of Human Rights Registration Number at the time bids are due. If the number has not been obtained, it must be provided within 5 business days after the date bids are due. This number shall be written or typed on the line in the Fair Employment Affidavit of Compliance (included in this document). The following link may be used to access the website where the number can be obtained:

http://www.illinois.gov/dhr/PublicContracts/Pages/Vendor_On_Line_Renewal.aspx

2.4 Taxes

This District is exempt, by law, from paying bidder Federal Excise Tax and Illinois Retailers' Occupational Tax. Therefore, the bidder shall exclude those taxes from his bid. The District's tax exemption number is E99923696. The bidder shall include all applicable taxes in his bid price.

2.5 Withdrawal of Bids

At any time prior to the scheduled bid opening, the bidder may withdraw his bid. In order to do so, he shall submit a written request to the Director of Management Services.

2.6 Laws and Regulations

The bidder who is awarded the contract shall comply with all laws of the United States of America, the State of Illinois, and all lawful regulations of the Rock River Water Reclamation District and the respective cities and villages in which the professional service, material or equipment supplied is to be performed respecting labor and compensation and all other statutes, ordinances, rules and regulations applicable and having the force of the law.

A. Illinois Regulations

1. **Prevailing Wage.** All Contracts for the Construction of Public Works are subject to the Illinois Prevailing Wage Act (820 ILCS 130/1-12). The undersigned, as Bidder, declares he will comply with prevailing wages in accordance with the Illinois Department of Labor Standards. The State of Illinois requires contractors and subcontractors on public works projects (including Rock River Water Reclamation District) to submit certified payroll records on a monthly basis, along with a statement affirming that such records are true and accurate, that the wages paid to each worker are not less than the required prevailing rate and that the contractor is aware that filing false records is a Class B Misdemeanor.

Transcripts of certified payroll shall be filed using the IDOL portal at <https://www2.illinois.gov/idol/Laws-Rules/CONMED/Pages/prevailing-wage-act.aspx>

2. **Public Act 83-1472.** Article 2 of Public Act 83-1472 provides that Illinois residents be employed on Illinois public works projects, provided there has been a period of excessive unemployment (5%) in the State of Illinois as defined in the Act; and, further, that Illinois workers are available and capable of performing the particular type of work involved.

B. Steel Products Procurement Act

Public Act 83-1030 entitled "Steel Products Procurement Act" requires that steel products used or supplied in performance of this contract or subcontract shall be manufactured or produced in the United States with three exceptions.

The provisions of this Section shall not apply:

1. Where the contract involves an expenditure of less than \$500.
2. Where the executive head of the public agency certifies in writing that (a) the specified products are not manufactured or produced in the United States in sufficient quantities to meet the agency's requirements, or (b) obtaining the specified products, manufactured or produced in the United States would increase the cost of the contract by more than 10%.
3. When its application is not in the public interest.

2.7 Terms

A. Payments to the Successful Bidder. If the District receives an acceptable invoice for conforming materials or service prior to the fifth day of the month, the District shall issue payment before the fifth day of the succeeding month. If received on or after the fifth day of the month, payment will be issued the following month.

B. Default. In case of default, the District will procure the materials or service described in this Invitation to Bid from other sources. The District shall hold the defaulting successful bidder responsible for any excess cost incurred. The defaulting successful bidder shall make such payment no more than 60 calendar days after the District notifies him, in writing, of such an occurrence.

C. Brand Substitutions. Bids will be considered for items complying substantially with specifications, provided deviations to the specifications are stated and items are described in detail. When offering alternate products, it is the responsibility of the bidder to outline alternatives and provide performance and technical data for evaluation. The Rock River Water Reclamation District will be the sole judge of whether such alternates are equivalent to the items specified. The District reserves the right to waive immaterial variations in the specifications.

D. Delivery Hours. Unless otherwise specified, all items must be delivered to: Rock River Water Reclamation District, 4850 Torque Drive, Loves Park, Illinois, Monday through Friday, between the hours of 7:30 A.M. and 3:00 P.M., excluding holidays.

In the unlikely event that the District is picketed by its employees or by a third party, or if any labor-management dispute between the District and its employees or third parties becomes known to the successful bidder, then in such event and during the course of any such picketing or labor-management dispute, the successful bidder shall continue to carry out the terms and conditions of this contract as if such pickets were not present or such labor-management dispute did not exist.

Time of delivery is part of the District's consideration of each bid.

E. F.O.B. Point and Shipping Charges. All prices shall be quoted F.O.B. destination, Rock River Water Reclamation District, Loves Park, Illinois. All shipping, handling and freight charges must be included in the bid amount.

F. Use of District Name Prohibited. In the absence of the District's written permission, the successful bidder shall not use the District's name in any form or medium of public advertising.

2.8 Quantities Estimated Only

The estimated quantities of the various items of work and materials, as set forth in the bid form, is approximate only and is given solely to be used as a uniform basis for the comparison of bids. The quantities actually required to complete the contract work may be less or more than so estimated, and if awarded a contract for the work specified, the Contractor further agrees that he will not make any claim for damages or for loss of profits or for an extension of time because of a difference between the quantities of the various classes of work assumed for comparison of bids and quantities of work performed.

2.9 Investigation

It shall be the responsibility of the bidder to make any and all investigations necessary to become thoroughly informed of what is required and specified in the bid document. No plea of ignorance by the bidder of conditions that exist or that may hereafter exist as a result of failure or omission on the part of the bidder to make necessary examinations and investigations will be accepted on a basis for varying the requirements of the District or the compensation of the bidder.

2.10 Addenda

If the District issues written addenda, such addenda shall become part of the contract documents. The District will distribute the addenda:

- A.** Not less than 3 working days prior to the bid opening date;
- B.** Via mail, email, or facsimile transmission;
- C.** To each recipient of the specifications, at either the:
 - 1. Address to which the District mailed the original bid document;
 - 2. Corrected address the prospective bidder subsequently furnished; or
 - 3. Email address prospective bidder furnished; or
 - 4. Facsimile number the prospective bidder sent the District.

In the absence of the prospective bidder's written notice of his email address or facsimile number, the District will provide addenda via mail.

A bidder that does not receive the District's addenda, and who has previously submitted a bid, shall not be relieved from any obligation in the bid he submitted.

2.11 Contract Form

No more than 10 business days following the contract award, the successful bidder shall submit a completed Contract Form to the District's Director of Management Services. The Contract Form is part of this Invitation to Bid. If the successful bidder fails to complete the

Contract Form within the specified time, he shall be in material default.

2.12 Contract Termination

A. Bidder's Unacceptable Performance. If the successful bidder fails to perform services or provide materials in conformity with this Invitation to Bid, the District shall notify him in writing. If the successful bidder fails to correct the performance deficiency to the District's satisfaction within five working days after he receives the District's notice, he shall be in default. If the same performance deficiency recurs despite the District's notification and the successful bidder's temporary correction, the successful bidder shall likewise be in default. The District may, at its sole discretion, terminate the **Manhole Frames & Lids** contract with the defaulting successful bidder, and remedy the matter under provisions set forth in Section 2.7B of this Invitation to Bid.

B. District's Action Following Contract Termination. If the contract is terminated, the District may, at its sole option:

1. request new **Manhole Frames & Lids** bids or
2. designate the next-low bidder to perform the **Manhole Frames & Lids** contract, provided that said next-low bidder agrees to his original bid terms.

The District may repeat this option until it obtains an acceptable **Manhole Frames & Lids** contract.

2.13 "No Bid" Response Form

In the event you elect not to bid, please fill out and return the attached "No Bid" form.

2.14 Indemnification Clause

Successful respondent/contractor shall protect, indemnify, hold and save harmless and defend the District, its officers, officials, employees, volunteers, and agents against any and all claims, costs, causes, actions and expenses, including but not limited to attorney's fees incurred by reason of a lawsuit or claim for compensation arising in favor of any person, including the employees, officers, independent contractors, or subcontractors of the successful respondent/contractor or District, on account of personal injuries or death, or damages to property occurring, growing out of, incident to, or resulting directly or indirectly from the performance by the successful respondent/contractor or subcontractor, whether such loss, damage, injury, or liability is contributed to by the negligence of the District or by premises themselves or any equipment thereon whether latent or patent, or from other causes whatsoever, except that the successful respondent/contractor shall have no liability for damages or the costs incident thereto caused by the sole negligence of the District.

The indemnification shall not be limited by a limitation on amount or type of damages payable by or for the successful respondent/contractor or its subcontractor under any employee benefits act including, but not limited, to the Workers' Compensation Act.

No inspection by the District, its employees, or agents shall be deemed a waiver by the District of full compliance with the requirements of the Contract. This indemnification shall not be limited by the required minimum insurance coverage in the Contract.

2.15 Force Majeure

The obligations of either the District or the successful bidder shall be suspended during the time as such party is prevented from complying therewith in whole or in part because of any cause, except financial, beyond the reasonable control of such party. In the event of either the District or the successful bidder being rendered unable wholly or in part by force majeure to carry out its obligations under the **Manhole Frames & Lids** contract, other than to make payments due, it is agreed that on such party giving notice and full particulars of such force majeure in writing to the other party as soon as possible after the occurrence of the cause relied on, then the obligations of the parties insofar as they are affected by such force majeure shall be suspended during the continuance of any inability so caused but for no longer period, and such cause shall as far as possible be remedied with all reasonable dispatch.

2.16 Insurance

A. The successful respondent/contractor, for the duration of the contract, shall maintain the following:

General Liability: \$1,000,000 combined single limit per occurrence for bodily injury, personal injury and property damage. If Commercial General Liability Insurance or other form with a general aggregate limit is used, either the general aggregate limit shall apply separately to this project or the general aggregate limit shall be twice the required occurrence limit.

Auto Liability: \$1,000,000 combined single limit per accident for bodily injury and property damage including coverages for owned, hired or non-owned vehicles, as applicable.

Workers' Compensation and Employers' Liability: Workers' Compensation limits as required by statute and Employers' Liability limits of \$500,000 per accident and \$500,000 per disease.

Umbrella: \$2,000,000 per occurrence/aggregate.

The policies shall contain, or be endorsed to afford Contractual Liability coverages for the following provisions in the General Liability and Automobile Liability coverages:

1. The District, its officers, officials, employees, and volunteers shall be covered as additional insureds as respects liability arising out of activities performed by or on insured's general supervision of the successful respondent/contractor, products and completed operations of the successful respondent/contractor, premises owned, occupied or used by the successful respondent/contractor, or automobiles owned, leased, hired, or borrowed by the successful respondent/contractor. The coverage shall contain no special limitations on the scope of protection afforded to the District, its officers, officials, employees, volunteers, or agents.
2. The successful respondent's/contractor's insurance coverage shall be primary insurance as respects the District, its officers, officials, employees, volunteers, and agents. Any insurance or self-insurance maintained by the District, its officers, official employees, volunteers, or agents shall be in excess of the successful respondent's/contractor's insurance and shall not contribute with it.
3. Any failure to comply with reporting provisions of the policies shall not affect

coverage provided to the District, its officers, officials, employees, volunteers, or agents.

The successful respondent's/contractor's insurance shall apply separately to each insured against whom claim is made or suit is brought, except with respect to the limits of the insurer's liability.

B. Proof of Insurance – Certificate of Insurance. No more than 10 calendar days subsequent to the District's issuance of an award letter and no later than 30 days before commencement to work, the successful respondent/contractor shall provide documentation including a Certificate of Insurance and primary, non-contributory additional insured endorsements to prove that it has obtained all required insurance and bonds. The District shall be the sole judge as to the acceptability of any such proof.

C. Correction of Successful Bidder's Insurance Deficiencies. If the District determines that the successful bidder's insurance or documentation does not conform to these specifications, the District shall inform said bidder of the non-conformity. If said bidder fails to provide conforming insurance or documentation within five calendar days of the District's notice, he shall be in default.

D. Best's Ratings.

1. **Alphabetical Rating.** For purposes of this Request for Bids, "insurer" shall mean any surety, insurance carrier, or other organization which proposes to provide an insurance policy or bond for the successful respondent/contractor. No insurer or surety rated lower than "A-," **Excellent**, in the current Best's Key Rating Guide shall be acceptable to the District.

2. **Financial Size Rating.** Provided an insurer's alphabetical rating is satisfactory, the District will examine said insurer's financial size rating.

- a) If Best classifies the insurer XII or larger, said insurer shall be acceptable to the District.
- b) If Best classifies the insurer as smaller than XII, but larger than VI, said **insurer shall be submitted to the District's Director of Management Services and/or the District's insurance consultant for review.**

Financial Size ratings less than VII are not acceptable and will disqualify the respondent/contractor.

E. Suitability of Insurance. The District shall be the sole judge of whether an insurer's rating is satisfactory. The District's decision shall be final and the District's bidding procedures contain no appeal provision.

2.17 Responsive/Responsible Bidder

A. Evaluation of Responsiveness. The responsiveness of bidders will be judged on the basis of the completeness of the bid submitted. To be responsive, a Bid must be submitted on the forms provided as part of the Bid Documents and comply with all the requirements of the Invitation to Bid.

B. Evaluation of Responsibility. To be judged as responsible, the bidder shall:

- 1. Have adequate financial resources for performance, the necessary experience,

organization, technical qualifications, and facilities, or a firm commitment to obtain such by subcontracts;

2. Be able to comply with the required completion schedule for the project;
3. Have a satisfactory record of integrity, judgment, and performance, including, in particular, any prior performance on contracts from the District;
4. Have an adequate financial management system and audit procedures, that provide efficient and effective accountability and control of all property, funds, and assets;
5. Conform to the civil rights, equal employment opportunity and labor law requirements of the Bid Documents.

FOR REVIEW PURPOSES ONLY

III

**DETAILED SPECIFICATIONS
INVITATION TO BID #21-204**

**MANHOLE FRAMES & LIDS
MAY 1, 2021 TO APRIL 30, 2022**

3.1 Scope and Intent

It is the intent of this document to specify minimum requirements that the successful bidder must meet in order for the District to obtain manhole frames and lids that meet the requirements of the Rock River Water Reclamation District.

All materials supplied, as part of this contract, shall be new and undamaged. District will contact vendor when an order is needed. Orders will be requested at different times throughout the year. No orders will be accepted after the bids are awarded unless requested by the District.

3.2 Frames & Lids

A. General

All frames and lids shall be gray iron as manufactured by the Neenah Foundry Company or equivalent. Frames and lids shall be of uniform quality, free of blowholes, shrinkage, distortion or other defects. They shall be smooth and thoroughly cleaned by shot-blasting. All gray iron shall conform to ASTM A48-83 Class 35B.

All frames and lids shall be manufactured true to pattern; all component parts shall fit together in a satisfactory manner. All frames & lids shall be unpainted. Frames & lids shall have continuously machined bearing surfaces to prevent rocking. As-cast dimensions may vary $\pm 1/16$ " per foot. Deviation from published weight shall not exceed $\pm 5\%$.

All frames and lids shall be heavy duty, suitable for highway traffic or H2O wheel loads of 16,000 lbs.

B. Manhole Lids

All manhole lids shall be the self-sealing type. All gaskets shall be of a material acceptable to the Rock River Water Reclamation District and shall be pre-installed and glued in place. The gasket shall be continuous and fit into a machined dovetail groove.

All lids shall have concealed pickholes of an acceptable design that do not allow water to enter the lid.

All pickholes shall be designed per the attached drawing, or District approved equivalent.

All lids shall have 2" high (horizontally) by 3/16" high (vertically) "SANITARY" lettering in the center of the lid.

When specified, lids shall be non-rocking with a pointed lug and graduated rack. Each tooth

in the rack shall vary diameter of the opening by 1/32".

Where required, cap screws or other hardware shall be stainless steel, with the lid designed such that they are countersunk.

C. Submittals

Manufacturer's shop drawings shall be submitted to the Rock River Water Reclamation District prior to manufacturing or shipping of the frames & lids to the Rock River Water Reclamation District. The Rock River Water Reclamation District shall retain the right to reject frames and lids not conforming to this bid document and/or approved shop drawings.

3.3 Warranty

Manufacturers shall unconditionally warrant their products for a period of two (2) years commencing on the date of delivery. Supplier shall, upon written notice, furnish labor and new materials to immediately replace and make good, without expense to the Rock River Water Reclamation District, faulty materials and equipment. Any such replacement shall likewise be covered by the same warranty period from subsequent delivery date.

All replacement parts shall be shipped F.O.B. to the Rock River Water Reclamation District north maintenance facility, located at 4850 Torque Drive, Loves Park, IL, within three (3) weeks of notification and shall be furnished at no additional cost to the Rock River Water Reclamation District.

3.4 Payments to the Successful Bidder

The successful bidder shall invoice the District monthly. Section 2.7A of this Invitation to Bid contains the District's general payment requirements.

3.5 Questions

Interested parties may direct questions concerning this Invitation to Bid to Terry Stoll, Collection Systems Maintenance Division Manager; 815-387-7588. The District will not interpret specifications for individual bidders. If the District determines that the specifications need to be clarified or revised, it will issue an addendum to all prospective bidders.

IV

**BID FORM
INVITATION TO BID #21-204**

**MANHOLE FRAMES & LIDS
MAY 1, 2021 TO APRIL 30, 2022**

To: BOARD OF TRUSTEES
 ROCK RIVER WATER
 RECLAMATION DISTRICT
 P. O. Box 7480
 ROCKFORD, ILLINOIS 61126-7480

From: _____
 (Individual, Partnership or Corporation)

 (Address of Individual, Partnership or Corporation)

Trustees:

I (We) the undersigned hereby propose to furnish **Manhole Frames & Lids** in compliance with the attached Introduction, General Specifications and Instructions, Detailed Specifications, Bid Form, Fair Employment Practices Affidavit of Compliance Form, Forms of Affidavit, and Contract Form.

The Undersigned also affirms and declares:

- A. That he (they) has (have) examined and is (are) familiar with all the related contract documents and found that they are accurate and complete and are approved by the undersigned.
- B. That he (they) has (have) carefully examined the scope of the required service, materials or equipment supplied, and that, from his (their) own investigation, has (have) satisfied himself (themselves) as to the nature and location of the delivery point, the character, quality and quantity of materials, and the kind and extent of equipment and other facilities needed for the performance of the service and provision of the materials, the general and local conditions and all difficulties to be encountered, and all other items which may, in any way, affect the services, materials, or equipment or their performance.
- C. That this bid is made without any understanding, contract or connection with any other person, partnership, or corporation making a bid for the same purposes, and is in all respects fair and without collusion or fraud; and that he (they) is (are) not barred from submitting a bid as a result of a bid-rigging or bid-rotating conviction.
- D. All goods and services provided in response to this request will be produced in compliance with all applicable requirements of Sections 6, 7 and 12 of the Fair Labor Standards Act, as amended, and of regulations and orders of the United States Department of Labor issued under Section 14 thereof.
- E. The firm which I (we) represent complies with all applicable requirements of the Americans with Disabilities Act (ADA), the Occupational Safety and Health Act (OSHA), rules and regulations of the US Department of Transportation (DOT), and the Federal Drug Free Work Place Act. If said firm is awarded a contract to provide the District's **Manhole Frames & Lids**, it will:

1. complete all OSHA, ADA, and DOT required supervisory, employee and customer training,
2. document compliance as required,
3. ensure that persons in safety-sensitive positions associated with loading, transportation, and delivery of the merchandise or service detailed in these specifications are subject to all required drug and alcohol testing and are properly licensed,
4. prepare and make available all required information and documentation, and
5. hold harmless and indemnify the District and the District's representatives as defined in Section 2.14 from all:
 - a. Suits, claims, or actions;
 - b. Costs, either for defense (including but not limited to reasonable attorney's fees and expert witness fees) or for settlements, and;
 - c. Damages of any kind (including but not limited to fines, actual, punitive, and compensatory damages) relating in any way to or arising out of the ADA or the OSHA, to which said firm is exposed or which it incurs in the execution of the contract.

F. The firm which I (we) represent has adopted and promulgated written sexual harassment policies that include, at a minimum, the following information:

1. the illegality of sexual harassment;
2. the definition of sexual harassment under Illinois State Law;
3. a description of sexual harassment, utilizing examples;
4. my (our) organization's internal complaint process including penalties;
5. the legal recourse, investigative and complaint process available through the Illinois Department of Human Rights and the Illinois Human Rights Commission;
6. directions on how to contact the Department and the Commission; and
7. protection against retaliation as provided by Section 6-101 of Illinois Human Rights Act.

Upon request, my (our) organization will provide the Illinois Department of Human Rights with the information described in F1 through F7 above.

In submitting this bid, I (we) agree that I (we) shall not withdraw this bid for a period of 60 calendar days following the scheduled bid opening. I (we) have carefully examined the nature of the service, materials, and equipment. The cost of all the service, materials, and equipment necessary to complete this contract is given in this bid.

Bid Form

Item No.	Quantity And Unit	Descriptive Title	Unit Price (In Figures)	Total Price (In Figures)
1	350 Ea.	Neenah R-1670 self-sealing, non-rocking, heavy-duty frames and lids (or equivalent)		
2	150 Ea.	Neenah R-1670 self-sealing, non-rocking, heavy-duty lids (or equivalent)		
3	20 Ea.	Neenah R-1647-A low-profile, self-sealing, non-rocking, heavy-duty frames and lids (or equivalent)		
4	50 Ea.	Neenah R-1772 Self-sealing, heavy-duty lids (or equivalent)		
5	15 Ea.	Neenah R-1915J self-sealing, heavy-duty frames and lids (or equivalent) with three (3) equidistant bolt holes in flanges on 30" diameter bolt circle for 1/2" anchor bolts		
6	20 Ea.	Neenah R-1973-1 riser casing and lid (or equivalent)		
Total Bid Price:				
				(In Figures)

In conformity with the requirements of the Detailed Specifications, I have submitted attached to this request for bids and incorporated in my bid by reference prices and part descriptions sufficient for the District to evaluate my organization's bid.

The undersigned acknowledges that he has received Addendum numbers _____, _____, _____, and realizes that all Addenda are considered part of the Contract.

Date: _____

Bidder: _____

(Print Name of Firm)

By: _____

(Authorized Rep's Signature)

(Print Street Address)

(Print Rep's Name)

(Print City, State, Zip)

(Print Rep's Title)

(Area Code and Phone Number)

(Facsimile Number)

NOTE: The Rock River Water Reclamation District, a Governmental Unit, pays neither Federal Excise Tax nor Illinois Retailers' Occupational Tax. The bidder shall exclude those taxes from his bid.

FOR REVIEW PURPOSES ONLY

**“NO BID” RESPONSE
TO
INVITATION TO BID #21-204**

If your firm is unable to submit a bid at this time, would you please provide the information requested in the space provided below and return to:

Rock River Water Reclamation District
P.O. Box 7480
Rockford, IL 61126-7480

Responses can be delivered in person to:

Rock River Water Reclamation District
3501 Kishwaukee Street
Rockford, IL 61109

Responses can also be faxed to:

Rock River Water Reclamation District
815-387-7538

We have received Invitation to Bid: **#21-204 Manhole Frames & Lids - May 1, 2021 to April 30, 2022**, opening at 2:00 P.M. on January 8, 2021.

Reason for not bidding: _____

BY: _____
Signature

Name & Title, Typed or Printed

Company Name

V
**FAIR EMPLOYMENT PRACTICES AFFIDAVIT OF COMPLIANCE
MANHOLE FRAMES & LIDS
MAY 1, 2021 TO APRIL 30, 2022**

NOTE: THE BIDDER MUST EXECUTE THIS AFFIDAVIT AND SUBMIT IT WITH ITS SIGNED BID. THE ROCK RIVER WATER RECLAMATION DISTRICT CANNOT ACCEPT ANY BID WHICH DOES NOT CONTAIN THIS AFFIDAVIT

_____, being first duly sworn, deposes and says that:
(Name of person making affidavit)

They are: _____ of _____
(Officer's Title) (Company Name)

that said company is and "Equal Opportunity Employer" as defined by Section 2000(e) of Chapter 21, Title 42 of the United States Code annotated and Federal Executive Orders #11375 which are incorporated herein by reference;

and that said company will comply with any and all requirements of Title 44 Admin. Code 750. APPENDIX A – Equal Opportunity Clause, Rules and Regulations, Illinois Department of Human Rights, which read as follows:

"In the event of the contractor's non-compliance with the provisions of this Equal Employment Opportunity Clause, the Illinois Human Rights Act or the Rules and Regulations of the Illinois Department of Human Rights ("Department"), the contractor may be declared ineligible for future contracts or subcontracts with the State of Illinois or any of its political subdivisions or municipal corporations, and the contract may be cancelled or voided in whole or in part, and such other sanctions or penalties may be imposed or remedies invoked as provided by statute or regulation. During the performance to this contract, the contractor agrees as follows:

1. That it will not discriminate against any employee or applicant for employment because of race, color, religion, sex, sexual orientation, marital status, national origin or ancestry, citizen status, age, physical or mental handicap unrelated to ability, military status or an unfavorable discharge from military service; and further that it will examine all job classifications to determine if minority persons or women are underutilized and will take appropriate affirmative action to rectify any such underutilization.
2. That, if he or she hires additional employees in order to perform this contract or any portion of this contract, he or she will determine the availability (in accordance with the Department's Rules and Regulations) of minorities and women in the areas from which he or she may reasonably recruit and he or she will hire for each job classification for which employees are hired in a way that minorities and women are not underutilized.
3. That, in all solicitations or advertisements for employees placed by him or her or on his or her behalf, he or she will state that all applicants will be afforded equal opportunity without discrimination because of race, color, religion, sex, sexual orientation, marital status, national origin or ancestry, citizenship status, age, physical or mental handicap unrelated to ability, sexual orientation, military status or an unfavorable discharge from military service.
4. That he or she will send to each labor organization or representative of workers with which he or she has or is bound by a collective bargaining or other agreement or understanding, a notice advising such labor organization or representative of the contractor's obligations under the Illinois Human Rights Act and the Department's Rules and Regulations. If any labor organization or representative fails or refuses to cooperate with the contractor in his or her efforts to comply with such Act and Rules and Regulations, the contractor will promptly so notify the Department and the contracting agency and will recruit employees from other sources when necessary to fulfill its obligations under the contract.
5. That he or she will submit reports as required by the Department's Rules and Regulations, furnish all relevant information as may from time to time be requested by the Department or the contracting agency, and in all respects comply with the Illinois Human Rights Act and the Departments Rules and Regulations.
6. That he or she will permit access to all relevant books, records, accounts and work sites by personnel of the contracting agency and the Department for purposes of investigation to ascertain compliance with the Illinois Human Rights Act and the Department's Rules and Regulations.
7. That he or she will include verbatim or by reference the provisions of this clause in every subcontract awarded under which any portion of the contract obligations are undertaken or assumed, so that the provisions will be binding upon the subcontractor. In the same manner as with other provisions of this contract, the contractor will be liable for compliance with applicable provisions of this clause by such subcontractors; and further it will promptly notify the contracting agency and the Department in the event any subcontractor fails or refuses to comply with the provisions. In addition, the contractor will not utilize any subcontractor declared by the Illinois Human Rights Commission to be ineligible for contracts or subcontracts with the State of Illinois or any of its political subdivisions or municipal corporations.

(Source: Amended at 32 111. Reg. 16484, effective September 23, 2008)"

IL Dept of Human Rights Registration No.: _____ Expiration Date: _____

Signature

Subscribed and sworn to before me this _____ day of _____, 20____.

Notary Public

VII

**CONTRACT
ROCK RIVER WATER RECLAMATION DISTRICT
ROCKFORD, ILLINOIS**

THIS CONTRACT, made and concluded this ____ day of _____, 20____, between the Rock River Water Reclamation District, Illinois, also known as "District," and _____ his/their executors, administrators, successors or assigns, known as "Contractor":

In consideration of the payments and contracts mentioned in the Bid attached hereto, to be made and performed by the District, the Contractor agrees with the District at his/their own proper cost and expense to do all the work, furnish all equipment, materials and all labor necessary to complete the work and furnish the merchandise in accordance with the specifications hereinafter described, and the District's requirements.

1. Scope

Both parties understand and agree that the Introduction, General Specifications and Instructions, Detailed Specifications, Bid Form, Fair Employment Practices Affidavit of Compliance Form, and Forms of Affidavit of the Invitation to Bid: **Manhole Frames & Lids**, all Addenda there to (if any), and any and all provisions required by law, are all essential documents of the contract, and are a part hereof, as if herein set out verbatim or as if attached, except for titles, subtitles, headings, table of contents and portions specifically excluded.

The Successful Bidder shall provide the District's **Manhole Frames & Lids** at the bid price, and a two (2) year warranty from date of final acceptance by the District. This project involves the purchase of Neenah R-1670 self-sealing, non-rocking manhole frames and lids (or equivalent); Neenah R-1670 self-sealing, non-rocking, heavy-duty lids (or equivalent); Neenah R-1647-A low-profile, self-sealing, non-rocking, heavy-duty frames and lids (or equivalent); Neenah R-1772 self-sealing, heavy-duty lids (or equivalent); Neenah R-1915J self-sealing, heavy-duty frames and lids (or equivalent) with three (3) equidistant bolt holes in flanges on 30" diameter bolt circle for 1/2" anchor bolts; Neenah R-1973-1 riser casing and lid (or equivalent), as specified in the Rock River Water Reclamation District *General Provisions and Technical Specifications for Sanitary Sewer Construction*.

2. Contract Price

The District shall pay to the Contractor, and the Contractor shall accept, in full payment for the performance of this Contract, subject to any additions or deductions provided for hereby, in current funds, the total contract price of:

_____ (\$_____).

The Contractor fully understands and agrees that his bid price, delivered F.O.B. 4850 Torque Dr., Loves Park, IL, will be the only basis for payment for the contract's duration, and that in the absence of changes to which the District and Contractor agree because of revisions to the scope of the **Manhole Frames & Lids**, this contract allows for no price

increases.

The District shall make payments to the Contractor, in accordance with and subject to the provisions of Section 4 of this Contract.

3. Contract Execution

The Contractor shall:

- A. Perform all services in a responsible manner, supplying only service, materials, or equipment that meets or exceeds the District's specifications;
- B. Deliver **Manhole Frames & Lids** in conformity with the specifications;
- C. Sustain all loss or damage arising out of the nature of the work to be done, or from any unforeseen obstruction or difficulty which he may encounter in the prosecution of the work, or from the action of the elements;
- D. Be responsible for all accidents he, his employees, or agents may incur in the contract's execution;
- E. Hold the District and its representatives harmless from liability of any nature or kind on account of use of any copyrighted or un-copyrighted composition, secret process, patented or unpatented invention, article or appliance furnished or used under this Contract. The Contractor shall likewise hold harmless and indemnify the District and its representatives from all:
 - 1. suits, claims, or actions,
 - 2. costs, either for defense or for settlements, and
 - 3. damagesto which the District or its representatives might be exposed by reason of an injury or alleged injury, to the person or property of another:
 - a. in the execution of the Contract, or
 - b. from actions the District or its representatives take on the Contractor's behalf, except in cases where such suits, claims, actions, or costs are found to be based on the District's negligence. For purposes of this paragraph, "its representatives" means "the Rock River Water Reclamation District's trustees, employees, agents, assigns, and their heirs;"
- F. Comply with all applicable requirements of the Americans with Disabilities Act (ADA), the Occupational Safety and Health Act (OSHA), rules and regulations of the US Department of Transportation (DOT), and the Federal Drug Free Work Place Act, and will:
 - 1. complete all OSHA, ADA, and DOT required supervisory, employee and customer training,
 - 2. document compliance as required,
 - 3. ensure that persons in safety-sensitive positions associated with loading, transportation, and delivery of the merchandise or service detailed in these specifications are subject to all required drug and alcohol testing and are properly licensed,

4. prepare and make available all required information and documentation, and
5. hold harmless and indemnify the District and the District's representatives as defined in Section 2.14 from all:
 - a. Suits, claims, or actions;
 - b. Costs, either for defense (including but not limited to reasonable attorney's fees and expert witness fees) or for settlements, and;
 - c. Damages of any kind (including but not limited to fines, actual, punitive, and compensatory damages) relating in any way to or arising out of the ADA or the OSHA, to which said firm is exposed or which it incurs in the execution of the contract.

- G.** Adopt and promulgate written sexual harassment policies that include, at a minimum, the following information:
1. the illegality of sexual harassment;
 2. the definition of sexual harassment under Illinois State law;
 3. a description of sexual harassment, utilizing examples;
 4. Contractor's internal complaint process including penalties;
 5. the legal recourse, investigative and complaint process available through the Illinois Department of Human Rights and the Illinois Human Rights Commission;
 6. directions on how to contact the Department and the Commission; and
 7. protection against retaliation as provided by Section 6-101 of Illinois Human Rights Act.

Upon request, Contractor will provide the Illinois Department of Human Rights with the information described in G1 through G7 above.

- H.** Maintain all specified insurance for the duration of the contract.
- I.** The Steel Products Procurement Act, Illinois Public Act 83-1030, requires that steel products used or supplied in performance of this Contract or subcontract shall be manufactured or produced in the United States with three exceptions, as explained in the Instructions to Bidders.
- J.** In the absence of the District's written permission, the Contractor shall not use the District's name in any form or medium of public advertising.
- K.** This Contract shall extend to and be binding upon the successors and assigns, and upon the heirs, administrators, executors, and legal representatives of the Contractor.

In consideration of and to induce the award of this Contract to him, the Contractor represents and warrants: that he is not in arrears to the District upon debt of the Contract and that he is not a defaulter, as surety, contractor or otherwise; that he is financially solvent and sufficiently experienced and competent to perform the work; that the work can be performed as called for by the Contract; that the facts stated in his proposal and the information given by him is true and correct in all respects, and that he is fully informed regarding all the conditions affecting the work to be done and labor

and materials to be furnished for the completion of this Contract and that his information was secured by personal investigation and research.

If the Contractor defaults, the District may procure Manhole Frames & Lids described in this Invitation to Bid, from other sources. In such an event, the price the District pays shall constitute the prevailing market price at the time of such purchase and the defaulting Contractor shall pay the District the difference between his bid price and the prevailing market price. The defaulting Contractor shall make such payment no more than 60 calendar-days after the District notifies him, in writing, of such an occurrence.

4. Payments to Contractor

A. Deliveries, Packing List, Delivery Receipt. At the time the District places an order, the District's authorized representative will issue the successful bidder a purchase order number. This will occur by telephone, fax or mail. The successful bidder shall affix the purchase order number to all packing lists, bills of lading, invoices and any other document related to the purchase order. The District may terminate the contract if the successful bidder fails to provide an acceptable packing list or delivery receipt at the time of delivery.

B. Invoicing Procedures, Payment to the Successful Bidder. The successful bidder shall affix the appropriate purchase order number to all invoices. In the absence of an acceptable invoice, the District may delay payment until its eventual receipt. If the District receives an acceptable invoice for conforming materials prior to the fifth day of the month, the District shall issue payment before the fifth day of the succeeding month. If received on or after the fifth day of the month, payment will be issued the following month.

5. Subcontracts

No part of the work herein provided for shall be sublet or subcontracted without the express written consent of the District, and in no case shall consent relieve said Contractor from the obligation herein entered into, or change the terms of this Contract.

6. Contractor's Responsibility

This Contract shall extend to and be binding upon the successors and assigns, and upon the heirs, administrators, executors, and legal representatives of the Contractor.

7. Counterparts

This Agreement may be executed and recorded in counterparts, each of which shall be deemed an original and all of which, when taken together, shall constitute one and the same instrument. The Parties hereby acknowledge and agree that facsimile signatures or signatures transmitted by electronic mail in so-called "pdf" format shall be legal and binding and shall have the same full force and effect as if an original of this Agreement had been delivered. Each of the parties (a) intend to be bound by the signatures on any document sent by facsimile or electronic mail, (b) are aware that the other party will rely on such signatures, and (c) hereby waive any defenses to the enforcement of the terms of this Agreement based on the foregoing forms of signature.

8. Time

The Contractor agrees to all delivery schedules specified in the Invitation to Bid.

9. Seals

IN WITNESS WHEREOF, the parties have hereunto set their hands, and are duly authorized to enter into such contracts on behalf of their respective organizations.

Name of Firm - Contractor

By _____
Authorized Signature

ATTEST:

By: _____

Its: _____

Rock River Water Reclamation District
Winnebago County, Illinois

By _____
Executive Director

ATTEST: _____
Director of Management Service

STATE OF ILLINOIS)
COUNTY OF WINNEBAGO)

On this ___ day of _____, 20____ before me, a notary public within and for said County, personally appeared Timothy S. Hanson and Julia Scott-Valdez, to me personally known, who, being each by me duly sworn did say that they are respectively, the Executive Director and Director of Management Services of the Rock River Water Reclamation District, named in the foregoing instrument, and that said instrument was signed and sealed in behalf of the District, and said Executive Director and Director of Management Services acknowledge said instrument to be the free act and deed of said District.

(SEAL)

Notary Public

FOR REVIEW PURPOSES ONLY

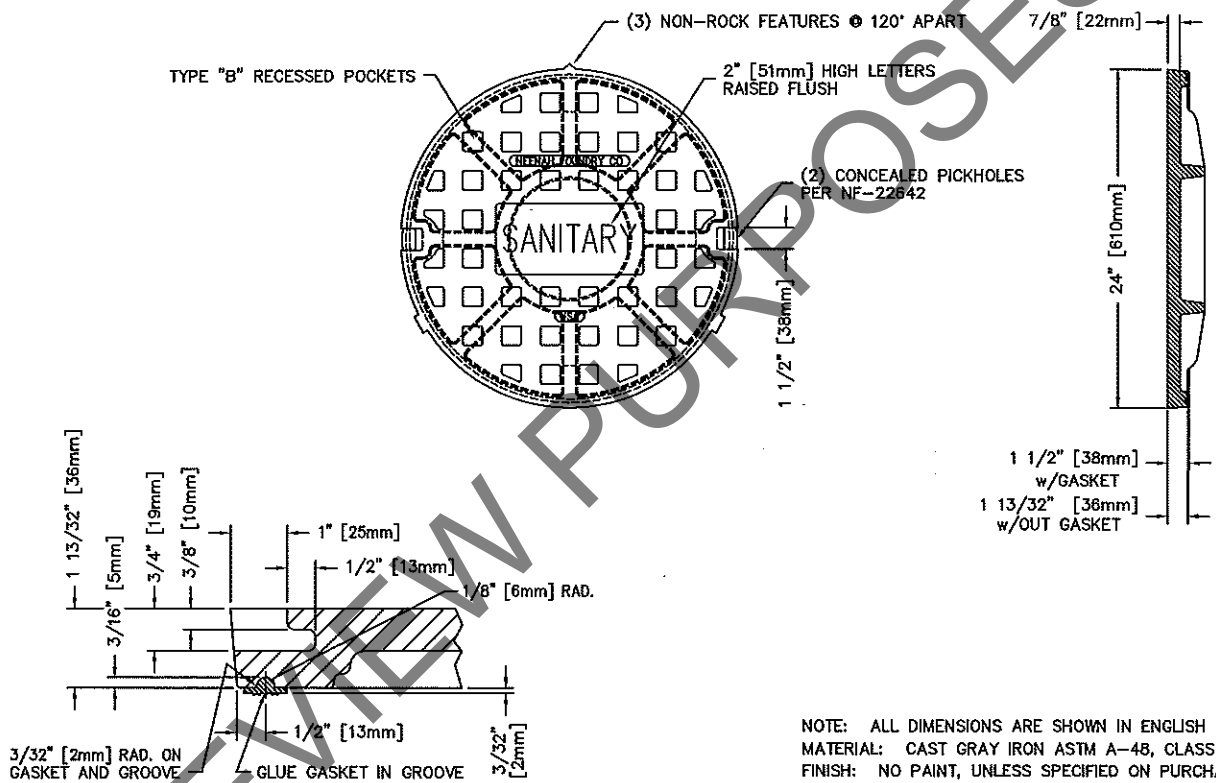

T-SEAL / CONCEALED PICK DETAIL
 HALF SCALE
 (GASKET NO. 02797)

NOTE: ALL DIMENSIONS ARE SHOWN IN ENGLISH AND [METRIC].
 MATERIAL: CAST GRAY IRON ASTM A-48, CLASS 35B
 FINISH: NO PAINT, UNLESS SPECIFIED ON PURCHASE ORDER
 WEIGHT: 138 LBS.

DR. RKB	SCALE 1/8"=1"	TITLE R-1670 NON-ROCK SOLID LID WITH AS-CAST T-SEAL, LTRD. "SANITARY"
CH. ELN		
APP. SPT	NEENAH FOUNDRY	
DATE 02-15-2017	NEENAH WISCONSIN 54956 PHONE 800-558-5075 LINCOLN, NEBRASKA 68529 PHONE 800-234-7466	
www.nfco.com		NF-16700345 B

FOR REVIEW PURPOSES ONLY

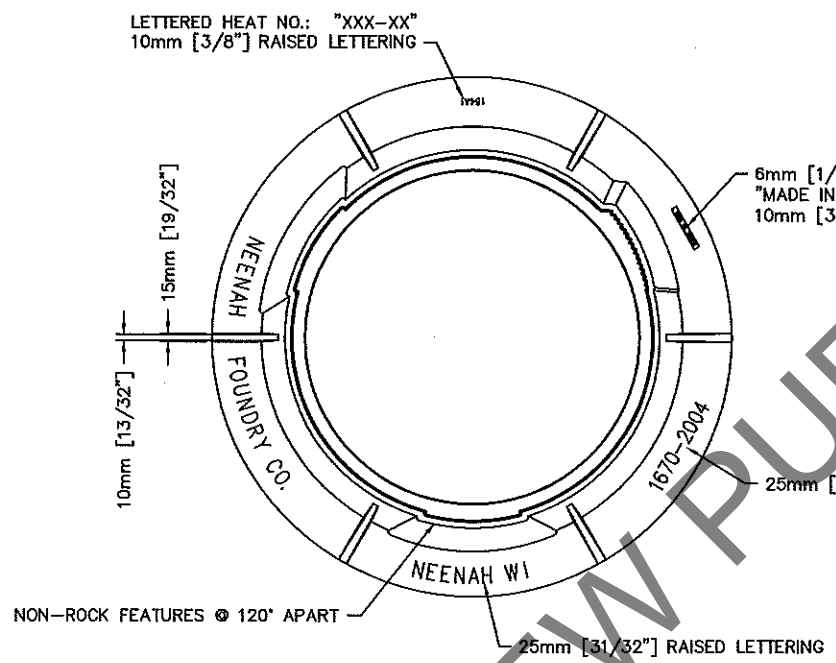

6mm [1/4"] RAISED LETTERING
"MADE IN USA" ON
10mm [3/8"] WIDE TAPE

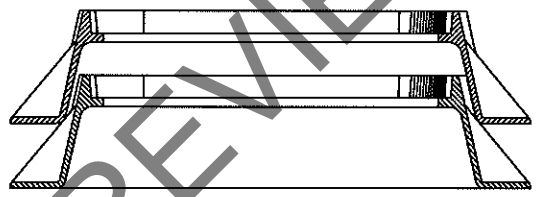
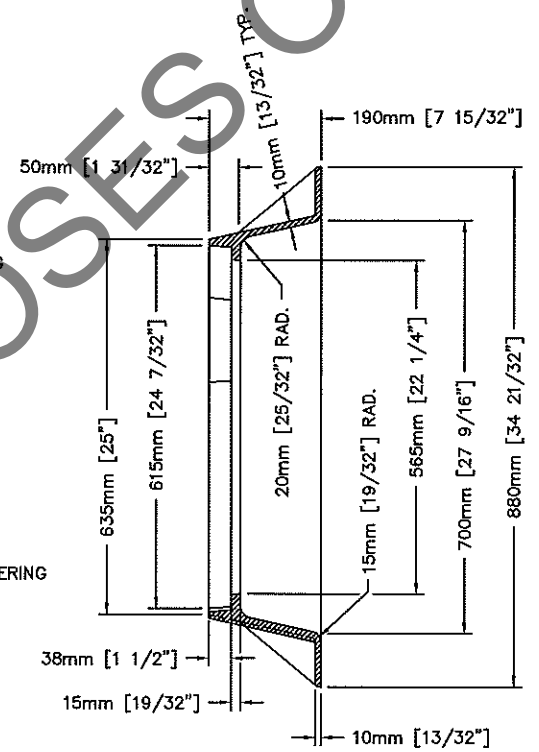

STACKED FRAMES DETAIL

NOTE: ALL DIMENSIONS ARE SHOWN IN ENGLISH AND [METRIC].
MATERIAL: CAST GRAY IRON ASTM A-48 CLASS 35B
FINISH: NO PAINT
WEIGHT: APPROX. 125#

DR.	CSK	SCALE	TITLE
CH.		1/8"=1"	R-1670 NON-ROCK FRAME
APP.		DIM CHK.	 NEENAH FOUNDRY COMPANY NEENAH WISCONSIN 54950
DATE	04-15-96		

CAD DWG. REF: 16702004.DWG-1

DATE 03-03-2003	DR. KMH	SCALE 1/8"=1"	APP. DIM CHK.
NEENAH FOUNDRY COMPANY FEDERAL ROADWAY #1895			
R-1915-J2 LID LETTERED "SANITARY"		NF-19155016 B	

NOTE: ALL DIMENSIONS SHOWN ARE IN ENGLISH AND [METRIC]
 MATERIAL: CAST GRAY IRON ASTM A-48, CLASS 35B
 FINISH: NO PAINT
 WEIGHT: 168#

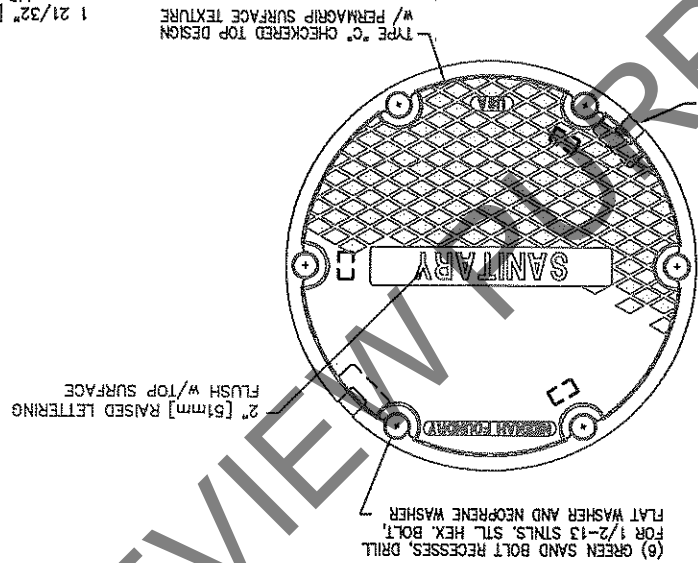
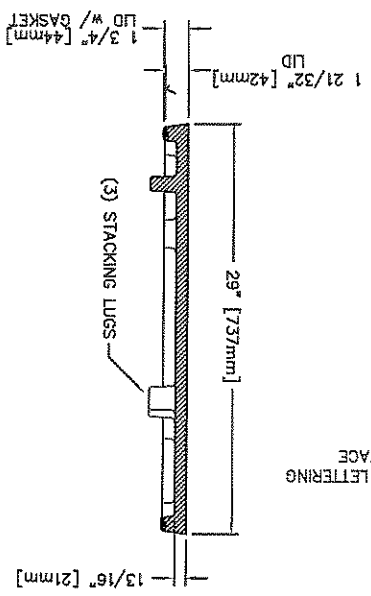

TYPICAL SECTION THRU LIFTHOLE
 SCALE 1:2

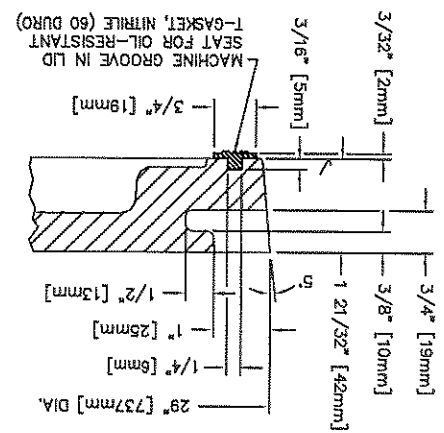

FOR REVIEW PURPOSES ONLY

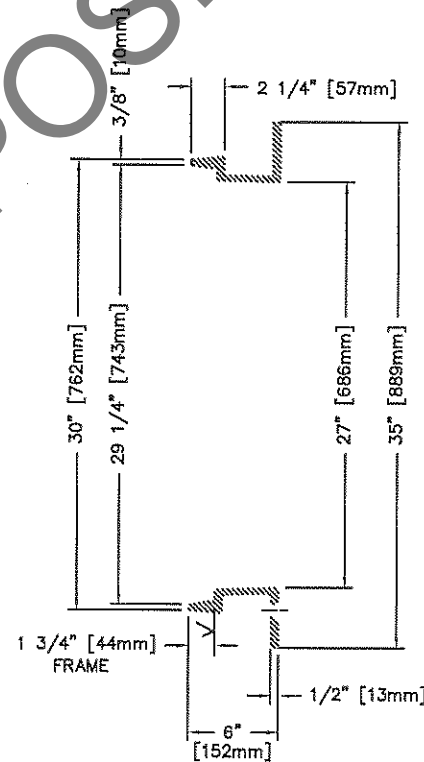
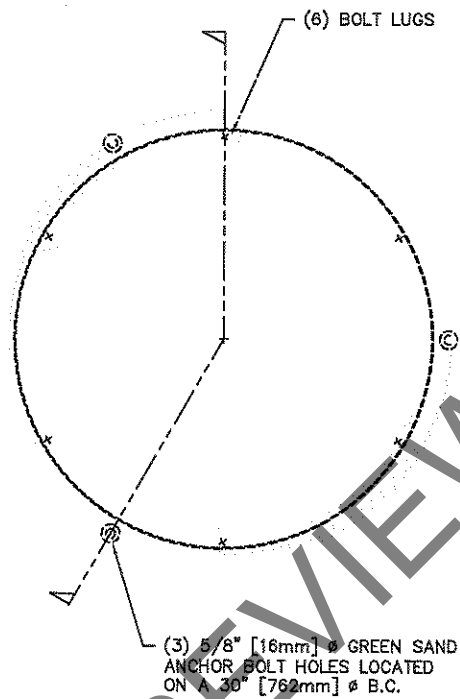

NOTE: ALL DIMENSIONS SHOWN ARE IN ENGLISH AND [METRIC].
 MATERIAL: CAST GRAY IRON ASTM A-48, CLASS 35B
 FINISH: NO PAINT
 WEIGHT: APPROX. 127#

DR. E. REMME	SCALE 1/8"=1"	TITLE R-1915-J FRAME
CH.		
APP.	DIM CHK.	NEENAH FOUNDRY COMPANY
DATE 01-22-96		NEENAH MESCON 04050
		NEF-19152101 B

FOR REVIEW PURPOSES ONLY

4X $\phi 5/8$ " ANCHOR HOLE
ON A $\phi 13 \frac{1}{2}$ " B.C.

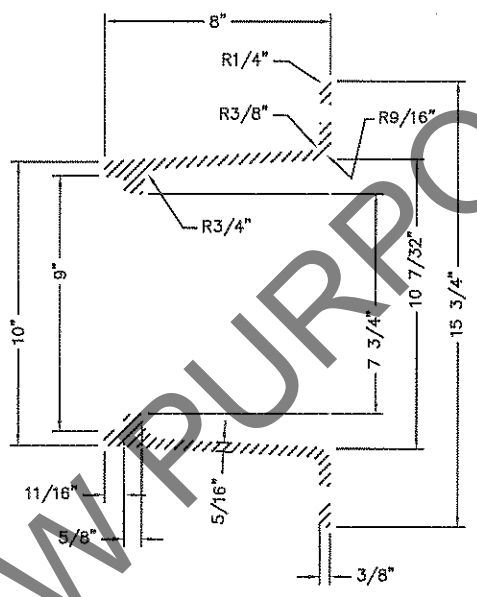
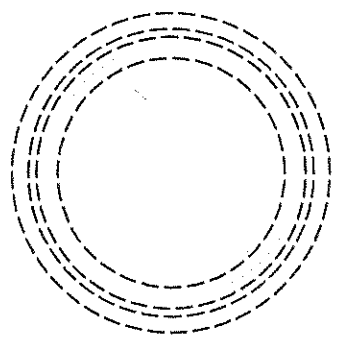

NOTES: MEETS LOADING REQUIREMENTS OF HS-25.
MADE IN THE USA.
QUALIFIES FOR 'LEED' CREDITS.
MATERIAL: CAST GRAY IRON ASTM A-48, CLASS 40A
FINISH: NO PAINT UNLESS SPECIFIED ON PURCHASE ORDER
WEIGHT: 36#

DR.	RKB/ELN	SCALE	TITLE
CH.		1/4"=1"	R-1973-AW MODERNIZED FRAME
APP.		DIM. CHK.	NEENAH FOUNDRY NEENAH WISCONSIN 54956
DATE	04-30-2012		NF-19732303 B
www.neenahfoundry.com		PHONE: 1-800-558-5075	

CAD DWG. REF: 19732303.DWG- 2

DATE	REVISION	ELN	INT
18-10-2012	ADDED NOTES AND CHG'D THE MATERIAL SPEC.		