

**Rock River Water Reclamation District
Rockford, Illinois**

Bidding Requirements and Contract Forms

for

**Clarifier Railings
(Primary Clarifier Tanks 5 - 10)**

Capital Project No. 1706

**Rock River Water Reclamation District
Rockford, Illinois**

**Bidding Requirements and Contract Forms
and
General Provisions and Technical Specifications
for
*Sanitary Sewer Construction***

for

**Clarifier Railings
(Primary Clarifier Tanks 5 - 10)**

Capital Project No. 1706

Board of Trustees

Donald Massier	President
Elmer Jones	Vice President
Richard Pollack	Clerk/Treasurer
John Sweeney	Trustee
Ben Bernsten	Trustee

Officials

Timothy S. Hanson	District Director
Christopher T. Baer, PE	Engineering Manager

Not to be used for bidding purposes

Index

I. Bidding Requirements

Article 1 Notice to Bidders

Article 2 Instructions to Bidders

- 1 General
- 2 Instructions to Bidders
- 3 General Instructions

Article 3 Detailed Specifications

- 1 General Requirements
- 2 Notification, Access & Special Considerations
- 3 Removal & Disposal of Existing Guardrail System, Complete
- 4 Removable 4-Foot Guardrail Sections
- 5 Davits
- 6 Davit Receiver Brackets
- 7 Section 05521 - Pipe & Tube Railings

II. Contract Forms

- Proposal
- Affidavit of Compliance
- Bid Bond
- Agreement
- Performance Bond
- Labor & Material Payment Bond

III. Equipment Specification Sheets

- Davits
- Davit Receiver Bracket

IV. General Provisions and Technical Specifications for Sanitary Sewer Construction (separate document incorporated by reference)

Not to be used for bidding purposes

Section I

Bidding Requirements

Article 1 — Notice to Bidders

The Rock River Water Reclamation District will receive sealed and signed bids for the Clarifier Railings (Primary Clarifier Tanks 5 – 10), Capital Project No. 1706, sewerage improvements at the Rock River Water Reclamation District offices, 3501 Kishwaukee Street, Rockford, Illinois until 1:00 p.m. on August 20, 2018 at which time and place all bids will be publicly opened and read aloud.

The Clarifier Railings (Primary Clarifier Tanks 5 – 10), Capital Project No. 1706 consists of the installation of new aluminum guardrails with toe plates and all other appurtenances as indicated on the plans and in the specifications.

Bidder's attention is called to Article 2 – Instructions to Bidders 3.8 requirements for Statement of Qualifications. Bidder must have a permanent business office within forty (40) miles of the District office at 3501 Kishwaukee Street in Rockford, IL.

All work shall be completed by November 30, 2018. Liquidated damages shall be \$300 per calendar day.

Copies of the specifications may be obtained by depositing Fifty Dollars (\$50.00) with the Rock River Water Reclamation District. The amount of the deposit for each set of specifications will not be refunded.

All construction will be done in accordance with specifications on file with the Rock River Water Reclamation District, including the *General Provisions and Technical Specifications for Sanitary Sewer Construction* (Current Edition) by the Rock River Water Reclamation District of Rockford.

Each proposal must be accompanied by the District Bid Bond form with an acceptable Bid Security attached, in the amount of ten percent (10 %) of the total bid price. This sum is a guarantee that, if the Proposal is accepted, a contract will be entered into and its performance properly secured.

A Mandatory Pre-Bid Meeting for this project will be held on August 9, 2018 at 10:00 a.m. at the RRWRD Board Room, 3501 Kishwaukee Street, Rockford, Illinois. All contractors that intend to bid on this project must attend the pre-bid meeting.

Bid documents may be obtained by contacting the Engineering Department at the Rock River Water Reclamation District, (815) 387-7660, 3501 Kishwaukee St. For more information, visit the District web site at www.rwrwd.dst.il.us. Plans and specifications are also available for viewing through the Northern Illinois Building Contractors Association, whose office is located at 1111 S. Alpine Rd, Rockford, IL.

The successful bidder will be required to furnish a satisfactory performance bond in the full amount of the bid or proposal. No bid shall be withdrawn without the consent of the District for a period of 60 days after the scheduled time of receiving bids.

The Rock River Water Reclamation District, reserves the right to reject any or all bids, or any part thereof, or to accept any bid or any part thereof, or to waive any formalities in any bids, deemed to be in the best interest of the Rock River Water Reclamation District.

Dated this 30th day of July, 2018

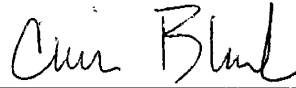

BY: Chris Black, Business Manager

Not to be used for bidding purposes

Article 2 — Instructions to Bidders

1 General

1.1 Scope and Intent

This section of the contract documents is concerned with furnishing detailed information and requirements for preparing bids to prospective bidders, bidders' responsibility, the preparation and the submission of bids, basis for awarding the contract and other general information concerned with bidding and executing the contract.

1.2 Contradictions

If in the case of apparent contradiction between or among the Contract Documents, the Contract Documents shall be consulted in the following order: Addenda, Agreement, Supplementary Drawings, Instructions to Bidders, Detailed Specifications, Plans, District General Provisions and Technical Specifications for Sanitary Sewer Construction. The language in the first such document in which language regarding the conflict, error or discrepancy occurs shall control.

2 Legal Requirements

2.1 Illinois Regulations

1. The undersigned, as Bidder, declares he will comply with prevailing wages in accordance with the Illinois Department of Labor Standards. The State of Illinois requires contractors and subcontractors on public works projects (including Rock River Water Reclamation District) to submit certified payroll records on a monthly basis, along with a statement affirming that such records are true and accurate, that the wages paid to each worker are not less than the required prevailing rate and that the contractor is aware that filing false records is a Class B Misdemeanor.

The certified payroll records must include the name, address, telephone number, social security number, job classification, hourly wages paid in each pay period, the number of hours worked each day, and the starting and ending time of work each day, for every worker employed on the project. Any contractor who fails to submit a certified payroll or knowingly files a false certified payroll is guilty of a Class B Misdemeanor. Certified payroll reports shall be submitted on standard IDOT forms.

2. Public Act 83-1030 entitled "Steel Products Procurement Act" requires that steel products used or supplied in performance of this contract or subcontract shall be manufactured or produced in the United States with three exceptions.

The provisions of this Section shall not apply:

- a. Where the contract involves an expenditure of less than \$500.
 - b. Where the executive head of the public agency certifies in writing that
 - i. the specified products are not manufactured or produced in the United States in sufficient quantities to meet the agency's requirements, or
 - ii. obtaining the specified products, manufactured or produced in the United States would increase the cost of the contract by more than 10%.
 - c. When its application is not in the public interest.
3. Public Act 96-929 (30 ILCS 570) provides that Illinois residents be employed on Illinois public works projects, provided there has been a period of excessive unemployment (5%) in the State

of Illinois as defined in the Act; and, further, that Illinois workers are available and capable of performing the particular type work involved.

4. Public Act 99-0933 requires that any party to a contract adopt and promulgate written sexual harassment policies that include, as a minimum, the following information:
 - a. the illegality of sexual harassment
 - b. the definition of sexual harassment under Illinois State law
 - c. a description of sexual harassment, utilizing examples
 - d. my (our) organization's internal complaint process including penalties
 - e. the legal recourse, investigative and complaint process available through the Illinois Department of Human Rights and the Illinois Human Rights Commission
 - f. directions on how to contact the Department and the Commission
 - g. protection against retaliation as provided by Section 6-101 of the Illinois Human Rights Act

Upon request, this information shall be provided to the Illinois Department of Human Rights and the District.

5. With regard to nondiscrimination in employment, the Contractor for this project will be required to comply with the Illinois Fair Employment Practices Commission's Rules and Regulations.
6. The Contractor for this project shall comply with the Occupational Safety and Health Act.
7. The Contractor for this project shall comply with the Federal Drug-Free Workplace Act.
8. Public Act 96-1416 requires the Certification of Clean Construction and Demolition Debris (CCDD) and uncontaminated soil prior to disposal at a CCDD fill site. The Contractor for this project shall comply with Public Act 96-1416 and be responsible for the certifications and any fees associated with the disposal at a CCDD fill site.
 - a. In the event that contaminated soil is uncovered on the project, the Contractor shall notify the District immediately. Any extra costs resulting from the presence of contaminated soil shall be evaluated in accordance with District General Provisions & Technical Specs for Sanitary Sewer Construction; General Conditions: Article 5 – Time Provisions and Article 8 – Changes.

2.2 Americans with Disabilities Act

The Contractor for this project will comply with all applicable requirements of the Americans with Disabilities Act of 1990 (ADA). The Contractor will hold harmless and indemnify Rock River Water Reclamation District (District) and their representatives from all:

1. suits, claims, or actions
2. costs, either for defense (including but not limited to reasonable attorney's fees and expert witness fees) or for settlement
3. damages of any kind (including but not limited to actual, punitive, and compensatory damages)

relating in any way to or arising out of the ADA, to which said firm is exposed or which it incurs in the execution of the contract.

3 General Instructions

3.1 Bidder's Responsibility

Bidders are cautioned not to submit proposals until having carefully examined the entire site of the proposed work and adjacent premises and the various means of approach and access to the site, and having made all necessary investigations to inform themselves thoroughly as to the facilities for delivering, placing and handling the materials at the site, and having informed themselves thoroughly as to all difficulties involved in the completion of all the work under this Contract in accordance with its requirements.

Bidders must examine the Plans, Specifications and other Contract Documents and shall exercise their own judgment as to the nature and amount of the whole of the work to be done and for the bid prices must assume all risk of variance, by whomsoever made, in any computation or statement of amount or quantities necessary to complete fully the work in strict compliance with the Contract Documents. The Bidder must satisfy himself by making borings or test pits, or by such methods as he may prefer, as to the character and location of the materials to be encountered or work to be performed. No pleas of ignorance of conditions that exist or that may hereafter exist, or of conditions or difficulties that may be encountered in the execution of the work under this Contract, as a result of failure to make the necessary examinations and investigations, will be accepted as an excuse for any failure or omission on the part of the Contractor to fulfill, in every detail, all of the requirements of the Contract Documents, or will be accepted as a basis for any claims whatsoever for extra compensation or for an extension of time.

The Contractor is responsible for verifying the location of all existing utilities in the project areas.

The Bidder, therefore, shall satisfy himself by such means as he may deem proper as to the location of all structures that may be encountered in construction of the work.

3.2 Addenda and Interpretations

No interpretation of the meaning of the Plans, Specifications, or other Contract Documents will be made to any bidder orally. Every request for such interpretation must be in writing addressed to the Rock River Water Reclamation District, 3501 Kishwaukee Street, Rockford, Illinois. To be given consideration, such request must be received at least five (5) days prior to the date fixed for the opening of bids. Any and all such interpretations and any supplemental instructions will be in the form of written addenda which, if issued, will be sent by email, fax, or certified mail with acknowledgement of receipt requested, to all prospective bidders, at the respective addresses furnished for such purposes, not later than three (3) days prior to the date fixed for the opening of bids. Failure of any bidder to receive any such addenda or interpretation shall not relieve said bidder from any obligation under his bid as submitted. All addenda so issued shall become part of the Contract Documents.

3.3 Laws and Regulations

The prospective bidder is warned that he must comply with all laws of the United States Government, State of Illinois, all ordinances and regulations of the District in the performance of the work under this contract. The Bidder's attention is specifically called to that provision of the General Conditions regarding the rate of wage to be paid on the work.

3.4 Quantities Estimated Only

Bidders are warned that the estimate of quantities of the various items of work and materials, as set forth in the proposal form, is approximate only and is given solely to be used as a uniform basis for the comparison of bids. The quantities actually required to complete the contract work may be less or more than so estimated, and if awarded a contract for the work specified, the Contractor further agrees that he will not make any claim for damages or for loss of profits or for an extension of time because of a difference between the quantities of the various classes of work assumed for comparison of bids and quantities of work actually performed.

3.5 Form, Preparation, and Presentation of Proposals

For particulars as to the quantity and quality of the supplies, materials and equipment to be furnished, and the nature and extent of the work or labor to be done, prospective bidders are referred to the Contract Documents, which may be examined or obtained at the office of the District.

Each bid will be submitted upon the prescribed proposal form. All blank spaces for bid prices must be filled in, in ink, with the unit or total sum or both for which the proposal is made. If the proposal contains any omissions, erasures, alterations, additions or items not called for in the itemized proposal, or contains irregularities of any kind, such may constitute sufficient cause for rejection of bid. In case of any discrepancy in the unit price or amount bid for any item in the proposal, the unit price as expressed in figures will govern. In no case is the agreement form to be filled out or signed by the bidder.

Should the Contractor desire to have an electronic proposal form e-mailed to him, the Contractor should contact the District's Engineering Department at (815) 387-7660. This form must be attached to the hard copy proposal form and appropriately signed and executed with the bid.

The bid must be verified and be presented on the prescribed form in a sealed envelope on or before the time and at the place stated in the Advertisement for Bids, endorsed with the name of the person, firm or corporation presenting it, the date of presentation, and the title of the work for which the bid is made. If forwarded by mail, the sealed envelope containing the proposal and marked as directed above, must be enclosed in another envelope addressed to Clerk of the Rock River Water Reclamation District, 3501 Kishwaukee Street, Rockford, Illinois, 61109 and be sent preferably by certified mail. The District will not accept facsimile generated bids.

3.6 Bid Security

Each proposal must be accompanied by the District Bid Bond form with an acceptable Bid Security attached, in the amount specified in Article One, Notice to Bidders. This sum is a guarantee that, if the Proposal is accepted, a contract will be entered into and its performance properly secured. The District's Bid Bond Form included in the bid packet must be used. No other Bid Bond form may be substituted.

Within ten (10) days after the opening of bids, the deposits of all but the three lowest bidders will be returned. The deposits of the remaining two unsuccessful bidders will be returned within three (3) days after the execution of the contract, or, if no such contract has been executed, within sixty (60) days after the date of opening bids. The deposit of the successful bidder will be returned only after he has duly executed the contract and furnished the required bond and insurance.

3.7 Affidavit of Compliance

Each proposal must be accompanied by an executed Affidavit of Compliance. A separate Affidavit of Compliance form is enclosed with the Proposal packet. Failure to submit an executed Affidavit of Compliance with the proposal may constitute sufficient cause for rejection of the bid.

3.8 Statement of Qualifications

Each proposal must be accompanied by a Statement of Qualifications certifying that the bidder is registered to do business in the State of Illinois, has a permanent business office within forty (40) miles of the District office at 3501 Kishwaukee Street in Rockford, IL, and provides documentation that the bidder possesses the appropriate financial, material, equipment, facility and personnel resources and expertise necessary to meet all contractual obligations. The bidder shall document no less than three (3) contracts for sanitary sewer system within the past five (5) years having equal or greater value to the bid being submitted. The District reserves the right to request additional information as needed to evaluate bids prior to making an award.

3.9 Comparison of Proposals

Bids on item contracts will be compared on the basis of a total computed price arrived at by taking the sum of the estimated quantities of each item, multiplied by the corresponding unit prices and including any lump sum bids on individual items, in accordance with the estimate of quantities set forth in the proposal form. Bids on lump sum contracts will be considered upon the basis of the lowest sum bid.

3.10 Acceptance of Bids and Basis of Award

No bidder may withdraw his bid after the scheduled closing time for receipt of bids, for at least sixty (60) days.

The contract will be awarded, if at all, to the lowest responsive, responsible bidder. The Rock River Water Reclamation District also reserves the right to reject any or all bids.

The bidder whose proposal is accepted shall enter into a written contract for the performance of the work and furnish the required bonds and insurance certificate within ten (10) days after written notice by the Engineering Manager of the District has been served on such bidder personally or by mailing a postpaid wrapper to such bidder at the address given in his proposal. If the bidder to whom the contract is awarded refuses or neglects to execute it or fails to furnish the required bond and insurance within five (5) days after receipt by him of the notice, the amount of his deposit shall be forfeited and shall be retained by the District as liquidated damage and not as a penalty. It being now agreed that said sum is a fair estimate of the amount of damages that the District will sustain in case said bidder fails to enter into a contract and furnish the required bond and insurance. No plea of mistake in the bid shall be available to the bidder for the recovery of his deposit or as a defense to any action based upon the neglect or refusal to execute a contract.

3.10.1 Evaluation of Responsiveness

The responsiveness of bidders will be judged on the basis of the completeness of the bid submitted. To be responsive, a Bid must be submitted on the forms provided as part of the Bid Documents and comply with all the requirements of the Instruction to Bidders.

3.10.2 Evaluation of Responsibility

To be judged as responsible, the bidder shall:

- a. Have adequate financial resources for performance, the necessary experience, organization, technical qualifications, and facilities, or a firm commitment to obtain such by subcontracts;
- b. Be able to comply with the required completion schedule for the project;
- c. Have a satisfactory record of integrity, judgment, and performance, including, in particular, any prior performance on contracts from the District;
- d. Have an adequate financial management system and audit procedures, that provide efficient and effective accountability and control of all property, funds, and assets;
- e. Conform to the civil rights, equal employment opportunity and labor law requirements of the Bid Documents.
- f. Have satisfactorily completed no less than three (3) sanitary sewer system contracts within the past five (5) years of equal or greater value to the bid being submitted.

3.11 The Rejection of Bids

The District reserves the right to reject any bid if the evidence submitted in the statement of the bidder's qualifications, or if investigation of such bidder fails to satisfy the District that such bidder is properly qualified to carry out the obligations and to complete the work contemplated therein. Any or all proposals will be rejected if there is reason to believe that collusion exists among the bidders. Conditional bids will not be accepted. The District reserves the right to reject any and all bids and to accept the bid which they deem most favorable to the interest of the District after all proposals have been examined and canvassed.

3.12 Insurance and Bonding

Contractor shall provide all necessary insurance and bonds required to complete the project. No more than ten (10) calendar days subsequent to the District's issuance of an award letter, the Contractor shall provide documentation to prove that he has obtained all required insurance and bonds. The District shall be the sole judge as to the acceptability of any such proof.

Contractor shall provide and maintain all insurance and bonds as required by the District.

3.12.1 General

The Contractor shall ensure that:

1. All insurance policies shall be specific to the project.
2. The insurance certificate shall state: This certifies that the insurance coverage meets or exceeds that required for Clarifier Railings (Primary Clarifier Tanks 5 – 10) Capital Project No. 1706.

3. The District shall be named as Additional Insured in all policies; this shall include the Owners Contractors Protective Policy option.
4. All completed operations coverages and bonds shall remain in force for a period of two (2) years following acceptance of the project and completed operations shall stay in force for two (2) years following completion of the project.

3.12.2 Insurance

The Contractor shall, for the duration of the contract and for two (2) years following project acceptance, maintain the following:

1. General Liability: \$1,000,000 combined single limit per occurrence for bodily injury, personal injury and property damage. If Commercial General Liability Insurance or other form with a general aggregate limit is used, either the general aggregate limit shall apply separately to this project or the general aggregate limit shall be twice the required occurrence limit. The Contractor shall provide "XCU" coverage.
2. Automobile Liability: \$1,000,000 combined single limit per accident for bodily injury and property damage including coverages for owned, hired or non-owned vehicles, as applicable.
3. Workers' Compensation and Employers Liability: Workers' Compensation limits as required by statute and Employers Liability limits of \$500,000 per accident and \$500,000 per disease.
4. Umbrella: \$2,000,000 per occurrence/aggregate for contracts valued at \$500,000 or over, or \$1,000,000 for contracts below \$500,000. \$10,000 is maximum allowable self-retained limit.
5. Errors and Omissions: If the Contractor performs professional services, he shall maintain errors and omissions insurance with a limit no lower than \$1,000,000 for the duration of the contract.

The policies shall contain, or be endorsed to contain, the following provisions in the General Liability and Automobile Liability Coverage's:

- a. Unless otherwise provided in paragraph "c" of this section, the District, its officers, officials, employees and volunteers shall be covered as additional insureds as respects liability arising out of activities performed by or on insured's general supervision of the Contractor, products and completed operations of the Contractor, premises owned, occupied or used by the Contractor, or automobiles owned, leased, hired or borrowed by the Contractor. The coverage shall contain no special limitations on the scope of protection afforded to the District, its officers, officials, employees, volunteers, or agents.
- b. Unless otherwise provided in paragraph "c" of this section, the Contractor's insurance coverage shall be primary insurance as respects the District, its officers, officials, employees, volunteers, and agents. Any insurance or self-insurance maintained by the District, its officers, officials, employees, volunteers, or agents shall be excess of the Contractor's insurance and shall not contribute with it.

- c. As an acceptable alternative to provisions “a” and “b” of this section, the Contractor may provide owner's and contractor's protective liability insurance with coverage limits, named insureds, and in conformity with all applicable specifications of this section.
- d. Any failure to comply with reporting provisions of the policies shall not affect coverage provided to the District, its officers, officials, employees, volunteers, or agents.
- e. The Contractor’s insurance shall apply separately to each insured against whom claim is made or suit is brought, except with respect to the limits of the insurer's liability.
- f. All Coverages — Each insurance policy required by this clause shall not be suspended, voided, canceled by either party, reduced in coverage, or in limits except after thirty (30) days' prior written notice by certified mail, return receipt requested, has been given to the District.

3.12.3 Best's Ratings

The District shall be the sole judge of whether or not said insurer's ratios are satisfactory. The District's decision shall be final and the District's bidding procedures contain no appeal provision.

1. Alphabetical Rating: For purposes of this Request for Bids, "insurer" shall mean any surety, insurance carrier, or other organization which proposes to provide an insurance policy or bond for the Contractor. No insurer or surety rated lower than "A-, Excellent" in the current *Best's Key Rating Guide* shall be acceptable to the District.
2. Financial Size Rating: Provided an insurer's alphabetical rating is satisfactory, the District will examine said insurer's financial size rating.
 - a. If Best classifies the insurer XII or larger, said insurer shall be acceptable to the District.
 - b. If Best classifies the insurer as smaller than XII, but larger than VI, said insurer shall be submitted to the District’s Business Manager and/or the District’s insurance consultant for review.

Financial Size ratings less than VII are not acceptable and will disqualify the Contractor.

3.12.4 Performance Bond and Labor & Materials Payment Bond Form

The Contractor shall provide a Performance Bond and Labor & Materials Payment Bond form acceptable to the District. The performance bond shall be for either 100% of the contract price or for the Contractor’s unit price times the estimated number of units, as applicable.

This Request for Bids contains a Performance Bond and a Labor & Material Bond form for the Contractor’s use.

If the Contractor fails to provide acceptable bonds within the specified time, he shall be in default.

3.12.5 Correction of Contractor's Insurance or Bond Deficiencies

If the District determines that the Contractor's insurance or bond documentation does not conform to these specifications, the District shall inform said Contractor of the non-conformity. If said Contractor fails to provide conforming insurance or bond documentation within five (5) calendar days of the District's deficiency notice, he shall be in default.

3.12.6 Indemnification Clause

Contractor shall protect, indemnify, hold and save harmless and defend the District, its officers, officials, employees, volunteers, and agents against any and all claims, costs, causes, actions and expenses, including but not limited to attorney's fees incurred by reason of a lawsuit or claim for compensation arising in favor of any person, including the employees, officers, independent contractors, or subcontractors of the Contractor or District, on account of personal injuries or death, or damages to property occurring, growing out of, incident to, or resulting directly or indirectly from the performance by the Contractor or subcontractor, whether such loss, damage, injury or liability is contributed to by the negligence of the District or by premises themselves or any equipment thereon whether latent or patent, or from other causes whatsoever, except that the successful bidder shall have no liability for damages or the costs incident thereto caused by the sole negligence of the District.

The indemnification shall not be limited by a limitation on amount or type of damages payable by or for the Contractor or its subcontractor under any employee benefits act including, but not limited, to the Workers Compensation Act.

No inspection by the District, its employees, or agents shall be deemed a waiver by the District of full compliance with the requirements of the Contract. This indemnification shall not be limited by the required minimum insurance coverages in the Contract.

3.13 Tax Exemption

The District is exempt, by law, from paying bidder Federal Excise Tax and Illinois Retailers' Occupational Tax. Therefore, the bidder shall exclude those taxes from his bid. The District's tax exemption number is E9992-3696-06. The bidder shall include all applicable taxes in his bid price.

Article 3 – Detailed Specifications

1 General Requirements

1.1 General

This article contains detailed specifications relating to proposal items. The work to be done under each item is discussed along with units for payment and measurement for payment. However, the descriptions given do not necessarily outline all the work to be done under any item. In addition, work shall conform to the following Technical Specifications: *Standard Specifications for Water and Sewer Main Construction in Illinois*, current edition, and *Rock River Water Reclamation District General Provisions and Technical Specifications for Sanitary Sewer Construction*. The term “*IDOT Standard Specifications*” shall mean the Illinois Department of Transportation’s *Standard Specifications for Road and Bridge Construction*, current edition. When referenced in applicable sections, work shall conform to the *IDOT Standard Specifications*.

Throughout these specifications, the term “Owner”, “District”, and “Engineer” shall be synonymous.

In case of apparent contradictions between *Article 3 - Detailed Specifications* and the *General Provisions and Technical Specifications for Sanitary Sewer Construction*, these *Detailed Specifications* shall govern.

Utility locations shown on the plans are based on the best information available at the time of design and are not guaranteed. The location and/or elevation of existing underground utilities, such as gas mains, water mains, electric lines, field tiles, irrigation pipes, etc., shall be determined by the Contractor. The Contractor shall assume full responsibility for location of all utilities.

Any construction not supervised by a District Inspector shall not be accepted.

No work shall be permitted on Sundays without prior approval by District Engineering Manager.

Suppliers shall be deemed to impliedly warrant that their products and all component materials incorporated into them are suitable and fit for the intended use of such products and shall be free from defect in material, workmanship or design, such warranty to run to the benefit of the District. The foregoing applies whether the products or component materials are specified in the Contract Documents or are of supplier’s design.

The District will not supervise, direct, control, have authority over or be responsible for the Contractor’s means, methods, techniques, sequences, procedures of construction, safety precautions and programs incident thereto, or for any failure of Contractor to comply with Laws and Regulations applicable to the furnishing or performance of the Work. The District will not be responsible for Contractor’s failure to perform or furnish the Work in accordance with the Contract Documents.

After the award of the contract and prior to starting work, the Contractor shall submit to the Engineer a satisfactory progress schedule or critical path schedule which will show the proposed sequence of work, and how the Contractor proposes to complete the various items of work by the completion date specified in this contract.

1.2 Submittals

The Contractor shall submit to the Engineer the items under 'Required Submittals' of each special provision prior to beginning any work. The Contractor shall perform the following:

1. Review each submittal.
2. Verify field dimensions.
3. Verify compliance with Contract documents.
4. Stamp submittals to certify the Contractor's review/approval.
5. Transmit reviewed submittals to the Engineer for approval.

The Contractor shall submit a list of all materials requiring the Engineer's color selection. The list shall include the manufacturers name and model number/name for each item. The Engineer may require additional color samples.

The Contractor shall allow two (2) weeks for the Engineer's review of most submittals. The Engineer reserves the right to withhold action on a submittal that requires coordination with other submittals, until all related submittals are submitted. No extension of time to perform the Contract will be authorized because of the Contractor's failure to make submissions to the Engineer in time for the Engineer to execute a thorough review.

The Engineer's approval of a submittal shall not be considered an order for additional, extra, or differing work, and shall not guarantee the accuracy of information or the effectiveness of the products provided in the submittal.

No work shall be fabricated by order of the Contractor, unless at the Contractor's risk, until review of submittals has been completed by the Engineer.

When the Contract Documents call for work to be performed in accordance with the manufactures' instructions, the manufacturers' instructions shall also be considered required submittals.

Should any material be installed in the Work for which a Material Safety Data Sheet (MSDS) is required to be retained by the District under State or Federal regulations, the installing subcontractor shall submit applicable MSDS forms to the Contractor for submission to the District upon completion of the project. Three (3) MSDS forms shall be submitted for each item. Only official OSHA MSDS forms shall be used; copies will not be accepted. The Contractor shall compile the MSDS forms and bind them into the Owners Manuals.

1.3 Pre-Bid Meeting (Mandatory)

A Mandatory Pre-Bid Meeting will be held at the RRWRD Board Room, 3501 Kishwaukee St., Rockford IL 61109 on August 9, 2018 at 10:00 a.m. Bids will not be accepted from Contractors who are not in attendance.

1.4 Required Submittals

1. Project Schedule

2 Notification, Access, & Special Considerations

2.1 General

Special Considerations:

1. The Contractor shall notify Warren Adam, Plant Maintenance Supervisor, (815)-871-0787, a minimum of forty-eight (48) hours in advance of construction.
2. Upon request and with five (5) minimum working days advance notice, Rock River Water Reclamation District will partially drain the tanks as needed and rinse the walls and slabs with water prior to the start of work. Any further cleaning required will be the responsibility of the Contractor.
3. The Contractor shall protect all existing equipment from damage of any kind, including but not limited to, dust control and water damage. Any damage occurring as a result of the Contractor's actions or negligence shall be corrected at no additional cost to the District.
4. Contractor staging and temporary storage of equipment and materials shall be as shown on Plan Sheet 2, specifically in the area indicated to the north of the primary clarifiers. The designated staging/storage areas shall be the only staging/storage areas utilized by the Contractor. Deliveries to the work site shall be accepted by the Contractor at the East treatment plant entrance (Guard Shack west of Kishwaukee Street). The District will not coordinate or be responsible for any deliveries that are inadvertently delivered to the District inventory shop.
5. The Contractor shall be allowed reasonable use of available on-site 120pV electrical power sources for hand held tools, ancillary lighting, etc., as long as it does not interfere with the normal functioning of District operations and as long as the usage does not develop into an abuse. Any power needs greater than 120-V shall be the Contractor's responsibility.
6. The Contractor shall provide sanitary facilities for use by all employees.
7. The Contractor's proposed sequence of work shall be submitted prior to beginning any work with the Project Schedule. The Contractor is responsible for developing the means, methods, and procedures for installation and is responsible for compliance with all OSHA and EPA regulatory requirements.

2.2 Required Submittals

1. Site Safety Plan indicating all safety measures the Contractor will employ to comply with all pertinent OSHA and EPA requirements.

2.3 Measurement and Payment

No payment will be made for costs associated with notification, access, and special considerations.

3 Removal and Disposal of Existing Guardrail System, Complete

3.1 General

This work shall consist of the complete removal of 1-1/2-inch galvanized steel railing and 4-inch aluminum toe board in locations shown on the plans. This work shall include the proper disposal of all materials generated by the removal of the guardrail and toe boards.

The Contractor shall be responsible for restoring, to the District's satisfaction, the concrete at the anchor points for the removed rail posts. The anchor bolts shall be removed and the area ground out prior to patching. The concrete repair grout shall be non-sag with integral corrosion inhibitor and be suitable for vertical applications.

3.2 Materials

Patching grout

3.3 Required Submittals

1. Concrete Repair Grout

3.4 Measurement and Payment

Payment for this work shall be based on the measured length of removal at the Contract unit price per Lineal Foot for **Removal and Disposal of Existing Guardrail System, Complete.**

4 Removable 4-foot Guardrail Sections

4.1 General

This work shall consist of furnishing and installing 4-foot removable guardrail sections and removable side-mount brackets as shown on the plans.

4.2 Materials

The material for the removable guardrail sections and side-mount brackets shall be in accordance with Specification Section 05521 and Detail 154 on Plan Sheet 5.

4.3 Required Submittals

1. Submittals for the Removable Guardrail sections shall be included with the guardrail submittals as described in Specification Section 05521.
2. Aluminum Side-mount Bracket.

4.4 Measurement and Payment

Payment for this work shall be based on the quantity installed at the Contract unit price per Each for **Removable 4' Guardrail Sections, Complete.**

5 Davits

5.1 General

This work shall consist of furnishing and installing twelve (12) davits for use with the removable wall brackets as described in Section 6 below. The davits shall be Best Hoist Pro-3 HD Series Davit or approved equal. See Section III for equipment data sheet.

5.2 Required Submittals

1. Aluminum Davits

5.3 Measurement and Payment

Payment for this work shall be paid for based on the quantity of davits installed at the Contract unit price per Each for **Davit**.

6 Davit Receiver Brackets

6.1 General

This work shall consist of furnishing and installing davit receiver brackets as shown on the plans and in accordance with the manufacturer's recommendations. The receiver brackets shall be compatible with the davits provided per Section 5 and shall allow for the davits to be removed and relocated as needed. The davit receiver bracket shall be Best Hoist Pro Series Permanent Bases 4 Point Wall Mount Base in 304 stainless steel. See Section III for equipment data sheet.

6.2 Required Submittals

1. Davit receiver bracket

6.3 Measurement and Payment

Payment for this work shall be paid for based on the quantity of davit receiver brackets installed at the Contract price per Each for **Davit Receiver Brackets**.

7 Section 05521 - Pipe and Tube Railings

Part 1 - General

This work shall consist of furnishing and installing 1 ½-inch diameter pipe and tube guard rails at the locations shown on the plans. The Contractor shall be responsible for verifying the measurements shown on the drawings, submitting installation plans that show the locations of the anchor points, the removable sections, the davit connection points, etc. The Contractor shall be responsible for repairing any damage caused by installation and the guard rail. The Contractor shall be responsible for cleaning any debris from the work area prior to moving on to the next work area. Any debris that enters the tank must be removed by the Contractor before the tank can be put back into operation. The Contractor must notify Plant Operations prior to entering the tank for debris removal and shall be responsible for following all OSHA requirements while working in and/or around the tanks.

Except as otherwise provided for herein, temporary support and final reinstallation or reattachment of all conduits, piping, fencing, railings, gratings and grating support channels, equipment, cables, etc., needed to complete the various work items shall be provided as necessary at no additional cost to the Owner.

1.1 Related Documents

- A. Drawings and general provisions of the Contract, including Sections 1 & 2 of General Provisions and Technical Specifications for Sanitary Sewer Construction, apply to this Section.

1.2 Summary

- A. Section Includes:

- 1. Aluminum pipe and tube railings.

- B. Related Sections:

- 1. General Provision and Technical Specifications for Sanitary Sewer Construction, Section 1 Article 11, "Payment".
- 2. General Provision and Technical Specifications for Sanitary Sewer Construction, Section 2 Article 3, "Working Drawings".

1.3 Performance Requirements

- A. Delegated Design: Design railings, including comprehensive engineering analysis by a qualified professional engineer, using performance requirements and design criteria indicated.
- B. General: Engineer railings to withstand structural loads indicated, determine allowable design working stresses of railing materials based on the following:
 - 1. Aluminum: The lesser of minimum yield strength divided by 1.65 or minimum ultimate tensile strength divided by 1.95.
- C. Structural Performance: Railings shall withstand the effects of gravity loads and the following loads and stresses within limits and under conditions indicated:
 - 1. Handrails and Top Rails of Guards:
 - a. Uniform load of 50 lbf/ ft. applied in any direction.
 - b. Concentrated load of 200 lbf applied in any direction.
 - c. Uniform and concentrated loads need not be assumed to act concurrently.

2. Infill of Guards:

- a. Concentrated load of 50 lbf applied horizontally on an area of 1 sq. ft..
- b. Infill load and other loads need not be assumed to act concurrently.

D. Thermal Movements: Allow for thermal movements from ambient and surface temperature changes acting on exterior metal fabrications by preventing buckling, opening of joints, overstressing of components, failure of connections, and other detrimental effects.

1. Temperature Change: 120 deg F, ambient; 180 deg F, material surfaces.

E. Control of Corrosion: Prevent galvanic action and other forms of corrosion by insulating metals and other materials from direct contact with incompatible materials.

1.4 Submittals

A. Submit product data under provision of Section 2 Article 3 "Working Drawings".

B. Product Data: For the following:

1. Manufacturer's product lines of welded railings.
2. Grout, anchoring cement, and paint products.

C. Shop Drawings (Working Drawings): Include plans, elevations, sections, details, and attachments to other work.

D. Delegated-Design Submittal: For installed products indicated to comply with performance requirements and design criteria, including analysis data signed and sealed by the qualified professional engineer responsible for their preparation.

E. Product Test Reports: Based on evaluation of comprehensive tests performed by a qualified testing agency, according to ASTM E 894 and ASTM E 935.

1.5 Quality Assurance

A. Source Limitations: Obtain each type of railing from single source from single manufacturer.

B. Welding Qualifications: Qualify procedures and personnel according to the following:

1. AWS D1.2/D1.2M, "Structural Welding Code - Aluminum."

1.6 Project Conditions

A. Field Measurements: Verify actual locations of walls and other construction contiguous with metal fabrications by field measurements before fabrication.

1.7 Coordination and Scheduling

- A. Coordinate installation of anchorages for railings. Furnish setting drawings, templates, and directions for installing anchorages, including sleeves, concrete inserts, anchor bolts, and items with integral anchors, that are to be embedded in concrete or masonry. Deliver such items to Project site in time for installation.
- B. Do not support railings temporarily by any means that do not satisfy structural performance requirement.

Part 2 - Products

2.1 Manufacturers

- A. Manufacturers: Subject to compliance with requirements, available manufacturers offering products that may be incorporated into the Work include, but are not limited to, the following:
 - 1. Aluminum Pipe and Tube Railings:
 - a. Golden Railings, Inc.
 - b. ATR Technologies, Inc.
 - c. Blum, Julius & Co., Inc.
 - d. Braun, J. G., Company; a division of the Wagner Companies.
 - e. CraneVeyor Corp.
 - f. Hollaender Manufacturing Company.
 - g. Kee Industrial Products, Inc.
 - h. Moultrie Manufacturing Company.
 - i. Pisor Industries, Inc.
 - j. Sterling Dula Architectural Products, Inc.; Div. of Kane Manufacturing.
 - k. Superior Aluminum Products, Inc.
 - l. Thompson Fabricating, LLC.
 - m. Tri Tech, Inc.
 - n. Tubular Specialties Manufacturing, Inc.
 - o. Tuttle Railing Systems; Div. of Tuttle Aluminum & Bronze, Inc.
 - p. SafeRack

2.2 Metals, General

- A. Metal Surfaces, General: Provide materials with smooth surfaces, without seam marks, roller marks, rolled trade names, stains, discolorations, or blemishes.
- B. Brackets, Flanges, and Anchors: Cast or formed metal of same type of material and finish as supported rails unless otherwise indicated.

2.3 Aluminum

- A. Aluminum, General: Provide alloy and temper recommended by aluminum producer and finisher for type of use and finish indicated, and with not less than the strength and durability properties of alloy and temper designated below for each aluminum form required.
- B. Extruded Bars and Tubing: ASTM B 221, Alloy 6063-T5/T52 or 6005-T5.
- C. Extruded Structural Pipe and Round Tubing: ASTM B 429, Alloy 6063-T6 or 6005-T5.
 - 1. Provide Standard Weight (Schedule 40) pipe, unless otherwise indicated.
- D. Drawn Seamless Tubing: ASTM B 210, Alloy 6063-T832 or 6005-T5.
- E. Plate and Sheet: ASTM B 209, Alloy 6061-T6.

2.4 Stainless Steel (not used)

2.5 Fasteners

- A. General: Provide the following:
 - 1. Aluminum Railings: Type 316 stainless-steel fasteners.
- B. Fasteners for Anchoring Railings to Other Construction: Select fasteners of type, grade, and class required to produce connections suitable for anchoring railings to other types of construction indicated and capable of withstanding design loads.
- C. Fasteners for Interconnecting Railing Components:
 - 1. Provide concealed fasteners for interconnecting railing components and for attaching them to other work, unless otherwise indicated.

2.4 MISCELLANEOUS MATERIALS

- A. Welding Rods and Bare Electrodes: Select according to AWS specifications for metal alloy welded.
 - 1. For aluminum railings, provide type and alloy as recommended by producer of metal to be welded and as required for color match, strength, and compatibility in fabricated items.
- B. Nonshrink, Nonmetallic Grout: Factory-packaged, nonstaining, noncorrosive, nongaseous grout complying with ASTM C 1107. Provide grout specifically recommended by manufacturer exterior applications.

2.5 FABRICATION

- Not to be used for bidding purposes
- A. General: Fabricate railings to comply with requirements indicated for design, dimensions, member sizes and spacing, details, finish, and anchorage, but not less than that required to support structural loads.
 - B. Assemble railings in the shop to greatest extent possible to minimize field splicing and assembly. Disassemble units only as necessary for shipping and handling limitations. Clearly mark units for reassembly and coordinated installation. Use connections that maintain structural value of joined pieces.
 - C. Cut, drill, and punch metals cleanly and accurately. Remove burrs and ease edges to a radius of approximately 1/32 inch unless otherwise indicated. Remove sharp or rough areas on exposed surfaces.
 - D. Form work true to line and level with accurate angles and surfaces.
 - E. Fabricate connections that will be exposed to weather in a manner to exclude water. Provide weep holes where water may accumulate.
 - F. Cut, reinforce, drill, and tap as indicated to receive finish hardware, screws, and similar items.
 - G. Connections: Fabricate railings with welded connections unless otherwise indicated.
 - H. Form changes in direction as follows:
 - 1. By bending.
 - I. Bend members in jigs to produce uniform curvature for each configuration required; maintain cross section of member throughout entire bend without buckling, twisting, cracking, or otherwise deforming exposed surfaces of components.
 - J. Close exposed ends of railing members with prefabricated end fittings.
 - K. Provide wall returns at ends of wall-mounted handrails unless otherwise indicated. Close ends of returns unless clearance between end of rail and wall is 1/4 inch (6 mm) or less.
 - L. Brackets, Flanges, Fittings, and Anchors: Provide wall brackets, flanges, miscellaneous fittings, and anchors to interconnect railing members to other work unless otherwise indicated.
 - 1. At brackets and fittings fastened to plaster or gypsum board partitions, provide crush-resistant fillers, or other means to transfer loads through wall finishes to structural supports and prevent bracket or fitting rotation and crushing of substrate.

- M. Provide inserts and other anchorage devices for connecting railings to concrete or masonry work. Fabricate anchorage devices capable of withstanding loads imposed by railings. Coordinate anchorage devices with supporting structure.
- N. For railing posts set in concrete, provide steel sleeves not less than 6.5 inches long with inside dimensions not less than 1/2 inch greater than outside dimensions of post, with metal plate forming bottom closure.
- O. Toe Boards: Where indicated, provide toe boards at railings around openings and at edge of open-sided floors and platforms. Fabricate to dimensions and details indicated.

2.8 FINISHES, GENERAL

- A. Comply with NAAMM's "Metal Finishes Manual for Architectural and Metal Products" for recommendations for applying and designating finishes.
- B. Protect mechanical finishes on exposed surfaces from damage by applying a strippable, temporary protective covering before shipping.
- C. Appearance of Finished Work: Variations in appearance of abutting or adjacent pieces are acceptable if they are within one-half of the range of approved Samples. Noticeable variations in the same piece are not acceptable. Variations in appearance of other components are acceptable if they are within the range of approved Samples and are assembled or installed to minimize contrast.
- D. Provide exposed fasteners with finish matching appearance, including color and texture, of railings.

2.9 ALUMINUM FINISHES

- A. Clear Anodic Finish: AAMA 611, AA-M12C22A31, Class II, 0.010 mm or thicker.

PART 3 - EXECUTION

3.1 EXAMINATION

3.2 INSTALLATION, GENERAL

- A. Fit exposed connections together to form tight, hairline joints.
- B. Perform cutting, drilling, and fitting required for installing railings. Set railings accurately in location, alignment, and elevation; measured from established lines and levels and free of rack.
 - 1. Do not weld, cut, or abrade surfaces of railing components that have been coated or finished after fabrication and that are intended for field connection by mechanical or other means without further cutting or fitting.

2. Set posts plumb within a tolerance of 1/16 inch in 3 feet.
 3. Align rails so variations from level for horizontal members and variations from parallel with rake of steps and ramps for sloping members do not exceed 1/4 inch in 12 feet .
- C. Corrosion Protection: Coat concealed surfaces of aluminum that will be in contact with grout, concrete, masonry, wood, or dissimilar metals, with a heavy coat of bituminous paint.
- D. Adjust railings before anchoring to ensure matching alignment at abutting joints.
- E. Fastening to In-Place Construction: Use anchorage devices and fasteners where necessary for securing railings and for properly transferring loads to in-place construction.

3.3 RAILING CONNECTIONS

- A. Welded Connections: Use fully welded joints for permanently connecting railing components. Comply with requirements for welded connections in "Fabrication" Article whether welding is performed in the shop or in the field.
- B. Expansion Joints: Install expansion joints at locations indicated but not farther apart than required to accommodate thermal movement. Provide slip-joint internal sleeve extending 2 inches beyond joint on either side, fasten internal sleeve securely to one side, and locate joint within 6 inches of post.

3.4 ANCHORING POSTS

- A. Use metal sleeves preset and anchored into concrete for installing posts. After posts have been inserted into sleeves, fill annular space between post and sleeve with nonshrink, nonmetallic grout, mixed and placed to comply with anchoring material manufacturer's written instructions.
- B. Cover anchorage joint with flange of same metal as post, welded to post after placing anchoring material.

3.5 ADJUSTING AND CLEANING

- A. Clean aluminum by washing thoroughly with clean water and soap and rinsing with clean water.
- B. Touchup Painting: Immediately after erection, clean field welds, bolted connections, and abraded areas of shop paint, and paint exposed areas with the same material as used for shop painting to comply with SSPC-PA 1 for touching up shop-painted surfaces.
1. Apply by brush or spray to provide a minimum 2.0-mil dry film thickness.

3.6 PROTECTION

- A. Protect finishes of railings from damage during construction period with temporary protective coverings approved by railing manufacturer. Remove protective coverings at time of Substantial Completion.

3.7 PAYMENT

- A. Payment for all labor, equipment, and materials needed to furnish and install the Pipe and Tube Railings and related items shall be made at the contract unit price per lineal foot for:
 - 1. 1-1/2" Dia. Aluminum Pipe Railing with 4" Toe Plate, Complete

Note: Payment shall be made at the contract unit prices for the various items identified regardless of the area where the work is performed.

END OF SECTION 05521

Not to be used for bidding purposes

Section II
Contract Forms

Proposal

Project: Clarifier Railings (Primary Clarifier Tanks 5-10)
Capital Project No. 1706

Location: Rock River Water Reclamation District
3333 Kishwaukee St., Rockford IL

Completion Date: November 30, 2018

Liquidated Damages: \$300/calendar day per each completion date deadline

To: Board of Trustees
Rock River Water Reclamation District
3501 Kishwaukee Street
Rockford, IL 61109

From: _____
(Individual, Partnership or Corporation, as case may be)

(Address of Individual, Partnership or Corporation)

Gentlemen:

I (We), the undersigned, hereby propose to furnish all materials, equipment, tools, services, labor, and whatever else may be required to construct and place in service the above subject Sanitary Sewer for the Rock River Water Reclamation District all in accordance with the plans and specifications, provided by the Rock River Water Reclamation District. The undersigned, also affirms and declares:

1. That I (we), have, examined and am (are) familiar with all the related contract documents and found that they are accurate and complete and are approved by the undersigned.
2. That I (we), have carefully examined the site of the work, and that, from my (our) investigation, has satisfied myself (ourselves) as to the nature and location of the work, the character, quality, and quantity of materials and the kind and extent of equipment and other facilities needed for the performance of the work, the general and local conditions and all

difficulties to be encountered, and all other items which may, in any way, effect the work or its performance.

3. That this bid is made without any understanding, agreement or connection with any other person, firm, or corporation making a bid for the same purposes, and is in all respects fair and without collusion or fraud; and that I (we) are not barred from bidding as a result of a bid-rigging or bid-rotating conviction.
4. That accompanying the Proposal is a Bidder's Bond in the amount specified in Article 1, Notice to Bidders, payable to the Board of Trustees of the Rock River Water Reclamation District, which it is agreed, shall be retained as liquidated damages by said Rock River Water Reclamation District if the undersigned fails to execute the Contract in conformity with the contract documents incorporated in the contract documents and furnish bond as specified, within ten (10) days after notification of the award of the contract to the undersigned.
5. The Bidder is of lawful age and that no other person, firm or corporation has any interest in this Proposal or in the Contract proposed to be entered into.
6. The Bidder is not in arrears to the Rock River Water Reclamation District, upon debt or contract, and is not a defaulter, as surety or otherwise, upon any obligation to the Rock River Water Reclamation District.
7. No officer or employee or person whose salary is payable in whole or in part by the District is, shall be or become interested, directly or indirectly as a contracting party, partner, stockholder, surety or otherwise, in this Proposal, or in the performance of the Contract, or in the work to which it is relates, or in any portion of the profits thereof.
8. The Bidder which I represent complies with all applicable requirements of the Americans with Disabilities Act (ADA) and the Occupational Safety and Health Act (OSHA) and that if said bidder is awarded a contract, it will complete all OSHA-required or ADA-required employee and customer training, will make available all required information, and will hold harmless and indemnify the District and the District's representatives.

In regard to participation in an approved Apprenticeship program, upon request, Contractor will be required to provide written proof of participation.

9. The undersigned, as Bidder, declares that he has adopted and promulgated written sexual harassment policies in accordance with Public Act 99-093 and will make this information available upon request.
10. The undersigned, as Bidder, declares he will comply with prevailing wages in accordance with the Illinois Department of Labor Standards. The State of Illinois requires contractors and subcontractors on public works projects (including the Rock River Water Reclamation District) to submit certified payroll records on a monthly basis, along with a statement affirming that such records are true and accurate, that the wages paid to each worker are not less than the required prevailing rate and that the contractor is aware that filing false records is a Class B Misdemeanor. The successful Bidder shall be responsible for verifying the prevailing wages each month and notifying all subcontractors of the appropriate monthly rates. [Prevailing wage rates may be found on the Illinois Department of Labor website at http://www.illinois.gov/idol/Laws-Rules/CONMED/Pages/Rates.aspx](http://www.illinois.gov/idol/Laws-Rules/CONMED/Pages/Rates.aspx).

The certified payroll records must include the name, address, telephone number, social security number, job classification, hourly wages paid in each pay period, the number of hours worked each day, and the starting and ending time of work each day, for every worker employed on the project. Any contractor who fails to submit a certified payroll or knowingly files a false certified payroll is guilty of a Class B Misdemeanor. Certified payroll reports shall be submitted on industry standard forms such as IDOT Statement of Compliance (SBE 348) or other approved equal.

11. The undersigned, as Bidder, declares he will comply with the Federal Drug Free Workplace Act.
12. The undersigned, as Bidder, declares he will comply with Public Act 83-1030 entitled "Steel Products Procurement Act".
13. The undersigned, as Bidder, declares he will comply with Public Act 96-929 (30 ILCS 570) regarding Illinois residents employment.
14. The undersigned, as Bidder, declares he will comply with non-discrimination in employment in accordance with the Illinois Fair Employment Practices Commissions Rules & Regulations.

15. The undersigned, as Bidder, declares that he currently participates in an apprenticeship or training program that is registered with the United States Department of Labor's Bureau of Apprenticeship and Training or other acceptable State of Illinois Department of Labor monitored program.

In submitting this bid, it is understood that the right is reserved by the Rock River Water Reclamation District to reject any and all bids. It is agreed that this bid may not be withdrawn for a period of sixty (60) days from the opening thereof.

The undersigned further declares that he (they) has (have) carefully examined the following items of work and that the cost of all the work to complete this project is given in this Proposal.

Not to be used for bidding purposes

Item No.	Quantity	Unit	Description	Unit Price (In Writing)	Unit Price (In Figures)	Total Price (In Figures)
1	400	LF	Removal & Disposal of Existing Guardrail System, Complete			
2	3,200	LF	1-1/2" Dia. Aluminum Pipe Railing with 4" Toe Plate, Complete			
3	60	EA	Removable 4' Guardrail Sections, Complete			
4	12	EA	Davits			
5	60	EA	Davit Receiver Brackets			
TOTAL BID PRICE:						
				(In Writing)		(In Figures)

The undersigned acknowledges receiving Addendum numbers _____, _____, _____, and realizes that all Addenda are considered part of the contract.

By: _____

Name: _____ Title: _____ Date: _____

Fair Employment Practices Affidavit of Compliance

PROJECT: Clarifier Railings (Primary Clarifier Tanks 5-10) Capital Project No. 1706

NOTE: THE BIDDER MUST EXECUTE THIS AFFIDAVIT AND SUBMIT IT WITH ITS SIGNED BID. THE ROCK RIVER WATER RECLAMATION DISTRICT CANNOT ACCEPT ANY BID WHICH DOES NOT CONTAIN THIS AFFIDAVIT

_____, being first duly sworn, deposes and says that:
(Name of person making affidavit)

They are: _____ of _____
(Officer's Title) (Company Name)

that said company is and "Equal Opportunity Employer" as defined by Section 2000(e) of Chapter 21, Title 42 of the United States Code annotated and Federal Executive Orders #11375 which are incorporated herein by reference;

and that said company will comply with any and all requirements of Title 44 Admin. Code 750. APPENDIX A – Equal Opportunity Clause, Rules and Regulations, Illinois Department of Human Rights, which read as follows:

"In the event of the contractor's non-compliance with the provisions of this Equal Employment Opportunity Clause, the Illinois Human Rights Act or the Rules and Regulations of the Illinois Department of Human Rights ("Department"), the contractor may be declared ineligible for future contracts or subcontracts with the State of Illinois or any of its political subdivisions or municipal corporations, and the contract may be cancelled or voided in whole or in part, and such other sanctions or penalties may be imposed or remedies invoked as provided by statute or regulation. During the performance to this contract, the contractor agrees as follows:

1. That it will not discriminate against any employee or applicant for employment because of race, color, religion, sex, sexual orientation, marital status, national origin or ancestry, citizen status, age, physical or mental handicap unrelated to ability, sexual orientation, military status or an unfavorable discharge from military service; and further that it will examine all job classifications to determine if minority persons or women are underutilized and will take appropriate affirmative action to rectify any such underutilization.
2. That, if he or she hires additional employees in order to perform this contract or any portion of this contract, he or she will determine the availability (in accordance with the Department's Rules and Regulations) of minorities and women in the areas from which he or she may reasonably recruit and he or she will hire for each job classification for which employees are hired in a way that minorities and women are not underutilized.
3. That, in all solicitations or advertisements for employees placed by him or her or on his or her behalf, he or she will state that all applicants will be afforded equal opportunity without discrimination because of race, color, religion, sex, sexual orientation, marital status, national origin or ancestry, citizenship status, age, physical or mental handicap unrelated to ability, sexual orientation, military status or an unfavorable discharge from military service.
4. That he or she will send to each labor organization or representative of workers with which he or she has or is bound by a collective bargaining or other agreement or understanding, a notice advising such labor organization or representative of the contractor's obligations under the Illinois Human Rights Act and the Department's Rules and Regulations. If any labor organization or representative fails or refuses to cooperate with the contractor in his or her efforts to comply with such Act and Rules and Regulations, the contractor will promptly so notify the Department and the contracting agency and will recruit employees from other sources when necessary to fulfill its obligations under the contract.
5. That he or she will submit reports as required by the Department's Rules and Regulations, furnish all relevant information as may from time to time be requested by the Department or the contracting agency, and in all respects comply with the Illinois Human Rights Act and the Departments Rules and Regulations.
6. That he or she will permit access to all relevant books, records, accounts and work sites by personnel of the contracting agency and the Department for purposes of investigation to ascertain compliance with the Illinois Human Rights Act and the Department's Rules and Regulations.
7. That he or she will include verbatim or by reference the provisions of this clause in every subcontract awarded under which any portion of the contract obligations are undertaken or assumed, so that the provisions will be binding upon the subcontractor. In the same manner as with other provisions of this contract, the contractor will be liable for compliance with applicable provisions of this clause by such subcontractors; and further it will promptly notify the contracting agency and the Department in the event any subcontractor fails or refuses to comply with the provisions. In addition, the contractor will not utilize any subcontractor declared by the Illinois Human Rights Commission to be ineligible for contracts or subcontracts with the State of Illinois or any of its political subdivisions or municipal corporations.

(Source: Amended at 32 I11. Reg. 16484, effective September 23, 2008)"

IL Dept of Human Rights Registration No.: _____ Expiration Date: _____

Signature

Subscribed and sworn to before me this _____ day of _____, 20_____.

Notary Public

Bid Bond

KNOW ALL MEN BY THESE PRESENTS, that we:

_____ (hereinafter called the Principal) and

_____ (hereinafter called the Surety)

a Corporation chartered and existing under the laws of the State of _____ with its principal offices in the City of _____ and authorized to do business in the State of Illinois are held and firmly bound onto the Rock River Water Reclamation District of Winnebago County, Illinois (District), in the full and just sum of: **TEN PERCENT (10%) OF THE TOTAL BID PRICE** good lawful money of the United States of America, to be paid upon demand of the District, to which payment will and truly to be made we bind ourselves, our heirs, executors, administrators, and assigns, jointly and severally and firmly by these presents.

WHEREAS, the Principal is about to submit, or has submitted to the District, a proposal for constructing Sanitary Sewers and Appurtenances.

WHEREAS, the Principal desires to file this bond, in accordance with law, to accompany this Proposal.

NOW THEREFORE, The conditions of this obligation are such that if the Proposal be accepted, the Principal shall, within ten days after the date of receipt of a written notice of award of Contract, execute a Contract in accordance with the Proposal and upon the terms, conditions, and prices set forth therein, in the form and manner required by the District, and execute a sufficient and satisfactory Contract Performance Bond payable to said District in an amount of one hundred percent (100%) of the Contract price (including alternates) in form and with security satisfactory to said District, then this obligation to be void, otherwise to be and remain in full force and virtue in law; and the Surety shall, upon failure of the Principal to comply with any or all of the foregoing requirements within the time specified above, immediately pay to the aforesaid District, upon demand, the amount hereof in good and lawful money of the United States of America, not as a penalty, but as liquidated damages.

IN TESTIMONY THEREOF, the Principal and Surety have caused these presents to be duly signed and sealed this ____ day of _____, 20__.

Principal

By _____

Name: _____

Title: _____

Date: _____

ATTEST:

Secretary

Surety

(Seal)

By _____

Name: _____

Title: _____

Date: _____

Not to be used for bidding purposes

Agreement

1. General

THIS AGREEMENT, made and concluded this__ day of _____, 2018, between the Rock River Water Reclamation District, Rockford, Illinois (District), acting by and through the Board of Trustees, and _____, his/their executors, administrators, successors or assigns:

2. Scope of Work

WITNESSETH: That for and in consideration of the payments and agreements made in the Proposal attached hereto, to be made and performed by the District and according to the terms expressed in the Bond referring to these presents, the Contractor agrees with the District at his/their own proper cost and expense to do all the work, furnish all equipment, materials and all labor necessary to complete the work in accordance with the plans and specifications hereinafter described, and in full compliance with all of the terms of this agreement and the requirements of the District and its representative.

And it is also understood and agreed that the Bidding Requirements, Detailed Specifications, Contract Forms, General Conditions, General Requirements, Technical Specifications, Plans, Addenda, and provisions required by law are all essential documents of the contract, and are a part hereof, as if herein set out verbatim or as if attached, except for titles, subtitles, headings, table of contents and portions specifically excluded.

3. Contract Price

The District shall pay to the Contractor, and the Contractor shall accept, in full payment for the performance of this Contract, subject to any additions or deductions provided for hereby, in current funds, the Total Contract Price of _____ and _____ 00/100 (\$_____).

Payments are to be made to the Contractor in accordance with and subject to the provisions of Section 7 of this Agreement, which is a part of this Contract.

4. Bond

The Contractor has entered into and herewith tenders a bond of even date herewith, in the penal sum of _____ and 00/100 (\$_____) to insure the faithful performance of this Contract, which said bond is hereby made a part of this Contract by reference.

5. Maintenance and Guarantee

The Contractor shall promptly repair, replace, restore or rebuild any imperfections that may arise and shall maintain satisfactory to the District all work for a period three years from the date of final acceptance of the Contract for trench settlement and for a period of two years all other work, except where periods of maintenance and guarantee are provided for. The Contractor shall, for this period, indemnify and save harmless the District, its officers and agents from any injury done to property or persons as a direct or alleged result of imperfections in the Contractors' work, and shall immediately assume and take charge of the defense of such action or suits in like manner and to all intents and purposes as if said actions and suits had been brought directly against the Contractor.

If the Contractor shall fail to repair, replace, rebuild or restore such defective or damaged work promptly after receiving notice given by the District, the District shall have the right to have the work done by others and to call on the Contractor and his bondsman to pay the costs thereof.

6. Contract Execution

IT IS EXPRESSLY UNDERSTOOD AND AGREED that the entire improvement shall be done in a thorough and workmanlike manner, under the direction and to the satisfaction of the District and in full compliance with all the requirements of its representative under them. All loss or damage arising out of the nature of the work to be done, or from any detention of unforeseen obstruction or difficulty which may be encountered in the prosecution of the work, or from the action of the elements, shall be sustained by the Contractor.

The Contractor will be held responsible for all accidents, and hereby agrees to indemnify and protect the District from all suits, claims, and actions brought against it, and all cost, and damages which the District may be put to by reason of an injury or alleged injury, to the person or property of another in the execution of this contract, or the performance of the work, or in guarding the same, or for any material used in its prosecution or in its construction.

Any person employed on the work who shall refuse or neglect to obey the directions of the District or its representative, or who shall be deemed by the District to be incompetent, or who shall be guilty of any disorderly conduct, or who shall commit any trespass on any public or private property in the vicinity of the work, shall at once be removed from the work by the Contractor when so requested by the District.

Any request to extend the contract completion date must be considered by the Board at the Board meeting prior to the then-existing contract termination date. Any deviation from this action will result in the liquidated damage clause in the contract to be exercised.

7. Payments to Contractor

The District hereby covenants and agrees, in consideration of the covenants and agreements in this Contract, specified to be kept and performed by the Contractor and subject to the conditions herein contained, and if the District receives an acceptable invoice prior to the tenth day of the month and receives approval of the work by the District Engineering Manager, the District shall issue payment before the fifth day of the succeeding month. If the District receives an acceptable invoice on or after the tenth day of the month, the District shall issue payment before the fifth day of the second succeeding month.

The District reserves the right at all times to refuse to issue payment in case the Contractor has neglected or failed to pay any subcontractors, workmen or employee on the work.

8. Subcontracts

No part of the work herein provided for shall be sublet or subcontracted without the express consent of the District, to be entered in the records, and in no case shall consent relieve the Contractor from the obligation herein entered into, or change the terms of this Agreement.

9. Contractor's Responsibility

This Contract shall extend to and be binding upon the successors and assigns, and upon the heirs, administrators, executors, and legal representatives of the Contractor.

In consideration of and to induce the award of this Contract to him, the Contractor represents and warrants: that he is not in arrears to the District upon debt of the Contract and that he is not a defaulter, as surety, contractor or otherwise; that he is financially solvent and sufficiently experienced and competent to perform the work; that the work can be performed as called for by the Contract; that the facts stated in his proposal and the information given by him is true and correct in all respects, and that he is fully informed regarding all the conditions affecting the work to be done and labor and materials to be furnished for the completion of this Contract and that his information was secured by personal investigation and research.

The Contractor shall pay not less than the prevailing wage rate as determined by the Department of Labor, to all laborers, workmen and mechanics performing work under this Contract. Contractor shall comply with current revisions of the wage standards; as required by law. The Contractor shall be responsible for verifying the prevailing wages each month and notifying all subcontractors of the appropriate monthly rates. Certified payroll reports shall be submitted on industry standard forms such as IDOT Statement of Compliance (Form SBE 348).

In regard to nondiscrimination in employment, Contractor will be required to comply with the Illinois Fair Employment Practices Commission's Rules and Regulations as provided herein.

The Contractor shall comply with the American Disabilities Act of 1990 (ADA). The Contractor will hold harmless and indemnify the District and their representatives from all:

- (a) suits, claims, or actions;
- (b) costs, either for defense (including but not limited to reasonable attorney's fees and expert witness fees) or for settlement, and;
- (c) damages of any kind (including but not limited to actual, punitive, and compensatory damages)

relating in any way to or arising out of the ADA, to which said firm is exposed or which it incurs in the execution of the contract.

Contractor shall also comply with Public Act 99-0933, which requires any party to a contract to adopt and enforce a written policy regarding sexual harassment that includes, as a minimum, the following information:

- (a) the illegality of sexual harassment
- (b) the definition of sexual harassment under Illinois State law;
- (c) a description of sexual harassment, utilizing examples;
- (d) my (our) organization's internal complaint process including penalties;
- (e) through the Illinois Department of Human Rights and the Illinois Human Rights Commission;
- (f) directions on how to contact the Department and the Commission; and
- (g) protection against retaliation as provided by Section 6-101 of the Illinois Human Rights Act.

Upon request this information will be provided to the Illinois Department of Human Rights. Upon District award of a contract, the District will be provided this information described no more than ten working days after the District issues its award notification.

The Contractor shall comply with Article 2 of Public Act 83-1472 which provides that Illinois residents be employed on Illinois public works projects, provided there has been a period of excessive unemployment (5%) in the State of Illinois as defined in the Act; and further, that Illinois workers are available and capable of performing the particular type work involved.

The Contractor shall comply with all rules and regulations of OSHA during the execution of this Contract.

The Contractor shall comply with the Federal Drug Free Workplace Act.

The Steel Products Procurement Act, Illinois Public Act 83-1030, requires that steel products used or supplied in performance of this Contract or subcontract shall be manufactured or produced in the United States with three exceptions, as explained in the Instructions to Bidders.

The Contractor shall comply with Public Act 96-1416 regarding the disposal of CCDD and uncontaminated soil at CCDD fill sites as explained in the Instructions to Bidders.

10. Time

Work under this Agreement shall be commenced upon written Notice to Proceed. The completion date for this project shall be November 30, 2018.

11. Liquidated Damages

The amount of liquidated damages shall be \$300.00 per calendar day.

Not to be used for bidding purposes

12. Seals

IN WITNESS WHEREOF, the parties have hereunto set their hands and seals, and such of them as are corporations have caused these presents to be signed by their duly authorized officers.

**Rock River Water Reclamation District
Winnebago County, Illinois**

(Seal)

By _____
President, Board of Trustees

ATTEST: _____
Clerk of the Board

Contractor

(Corporate Seal)

By _____
Contractor's Officer

Name: _____

Title: _____

Date: _____

ATTEST: _____

Not to be used for bidding purposes

Performance Bond

KNOW ALL MEN BY THESE PRESENTS, that WHEREAS, the Rock River Water Reclamation District has awarded to: _____ hereinafter designated as the “Principal”, a contract, dated, _____, for the Rock River Water Reclamation District.

WHEREAS, said Principal is required under the terms of said Contract to furnish a bond for the faithful performance of said Contract (the “Bond”);

NOW, THEREFORE, we the Principal and _____, as Surety, are firmly bound unto the Rock River Water Reclamation District in the penal sum of _____ Dollars (\$ _____) lawful money of the United States for the payment of which sum well and truly to be made, we bind ourselves, our heirs, executors, administrators, successors and assigns, jointly and severally firmly by these presents for a performance bond. The conditions of this obligation is such that if the said Principal does well and faithfully performs all the conditions and covenants of said Contract, according to the true intent and meaning thereof, upon its part to be kept and performed, then the above obligation is to be null and void, otherwise to remain in full force and effect.

THE CONDITION OF THIS OBLIGATION IS SUCH, that if the above bounden Principal, its heirs, executors, administrators, successors or assigns, shall in all things stand to and abide by, and well and truly keep and perform the covenants, conditions and agreements in the said Contract, including the provisions for liquidated damages in the said Contract, any changes, additions or alterations thereof made as therein provided, on its part, to be kept and performed at the time and in the manner therein specified, and in all respects according to their true intent and meaning, and shall indemnify and save harmless the Rock River Water Reclamation District, its officers and agents, as therein stipulated, then this obligation shall become null and void; otherwise it shall be and remain in full force and effect. And the said Surety, for value received, hereby stipulates and agrees that no change, extension of time, alteration or addition to the terms of the Contract or to the work to be performed thereunder or the specifications accompanying the same and no inadvertent overpayment of progress payments shall in any way affect its obligations on this Bond, and it does hereby waive notice of any such change, extension of time, alteration or addition to the terms of the Contract or to the work or to the specifications or of any inadvertent overpayment of progress payments. The Rock River Water Reclamation District shall be named as beneficiary on this Performance Bond.

IN WITNESS WHEREOF, the above-bounden parties have executed this instrument under their seal this _____ day of _____, 20_____, the name and corporate seal of each corporate party being hereto affixed and these presents duly signed by its undersigned representative, pursuant to authority of its governing body.

CONTRACTOR

SURETY

Contractor Firm Name:

By: _____

By: _____ Signature

Attorney-in-Fact

Title

Resident Agent

ATTEST:

Corporate Secretary (Corporations only)

Not to be used for bidding purposes

Labor & Material Payment Bond

TO: _____ Contractor Name
_____ Contractor City, State

KNOW ALL MEN BY THESE PRESENTS

That _____ (Contractor)

as Principal, and _____

a corporation of the State of _____ as Surety, are held and firmly bound unto the Rock River Water Reclamation District, as Obligee, for the use and benefit of claimants as hereinafter defined in the amount of

_____ Dollars (\$ _____), for the payment where of Principal and Surety bind themselves, their heirs, executors, administrators, successors and assigns, jointly and severally, firmly by these presents.

WHEREAS, Principal has by written agreement dated _____ 20____ Entered into a Contract with Obligee for _____ in accordance with contract documents prepared by the Rock River Water Reclamation District which Contract is by reference made a part hereof, and is hereinafter referred to as "the Contract".

NOW, THEREFORE, THE CONDITION OF THIS OBLIGATION is such that if Principal shall promptly pay for all laborers, workers and mechanics engaged in the work under the Contract, and not less than the general prevailing rate of hourly wages of a similar character in the locality in which the work is performed, as determined by the State of Illinois Department of Labor pursuant to the Illinois Compiled Statutes 280 ILCS 130 / 1-12 et.seq. and for all material used or reasonably required for use in the performance of the Contract, then this obligation shall be void; otherwise it shall remain in full force and effect.

1. A claimant is deemed as any person, firm, or corporation having contracts with the Principal or with any of Principal's subcontractors for labor or materials furnished in the performance of the Contract on account of which this Bond is given.
2. Nothing in this Bond contained shall be taken to make the Obligee liable to any subcontractor, material man or laborer, or to any other person to any greater extent than it would have been liable prior to the enactment of The Public Construction Bond Act, approved June 20, 1931, as amended; provided further, that any person having a claim for labor and materials furnished in the performance of the Contract shall have no right of action unless he shall have filed a verified notice of such claim with the Obligee within 180 days after the date of the last item of work or the furnishing of the last item of materials, which claim shall have been verified and shall contain the name and address of the claimant, the business address of the claimant within the State of Illinois, if any, or if the claimant be a foreign corporation having no place of business within the State the principal place of

business of the corporation, and in all cases of partnership the names and residences of each of the partners, the name of the Contractor for the Oblige, the name of the person, firm or corporation by whom the claimant was employed or to whom such claimant furnished materials, the amount of the claim and a brief description of the public improvement for the construction or installation of which the contract is to be performed. No defect in the notice herein provided for shall deprive the claimant of its right of action under the terms and provisions of this Bond unless it shall affirmatively appear that such defect has prejudiced the rights of an interested party asserting the same.

3. No action shall be brought on this Bond until the expiration of 120 days after the date of the last item of work or of the furnishing of the last item of material except in cases where the final settlement between Oblige and the Contractor shall have been made prior to the expiration of the 120 day period, in which case action may be taken immediately following such final settlement; nor shall any action of any kind be brought later than 6 months after the acceptance by the Oblige of the work. Such suit shall be brought only in the circuit court of this State in the judicial district in which the Contract is to be performed.
4. Surety hereby waives notice of any changes in the Contract, including extensions of time for the performance thereof.
5. The amount of this Bond shall be reduced by and to the extent of any payment or payments made in good faith hereunder.
6. The Principal and Surety shall be liable for any attorneys fees, engineering costs, or court costs incurred by the Oblige relative to claims made against this Bond.

Signed and Sealed this _____ day of _____, 2018.

CONTRACTOR SURETY
Contractor Firm Name

By: _____
Signature

By: _____
Attorney-in-Fact

Title Resident Agent

ATTEST:

Corporate Secretary (Corporations only)

Section III

Equipment Specification Sheets

- **Davits**
- **Davit Receiver Bracket**

PRODUCT DESCRIPTION

The PRO-3 HD Series Davit is designed to support Pro-3 HD Series davit arm up to a maximum offset of 48”(1220mm) for Personal Fall Arrest Systems (PFAS’s), Confined Space Entry / Retrieval and rescue applications. Provision is made for the mounting of various winches and SRL’s to the structure on the rear of the vertical post. Other mounting options are possible using a variety of adaptor brackets available from Tuff Built Products.



1 piece Davits are available in a variety of heights to tailor a system to your specific application requirements.

Mast and base set up and tear down quickly using no tools into compact, lightweight parts for transport and storage.

Exclusive TUFF-KLIK connectors* eliminate adjustment pins that can be easily damaged or lost.

*Patent Pending

APPLICATION RESTRICTIONS

1. This product **MUST BE** used only with Pro-Series mounting bases from Tuff Built Products Inc. All accessories **MUST BE** designed, manufactured, and/or approved by Tuff Built Products Inc.
2. All system components **MUST BE** installed, inspected, maintained, and used in accordance with the manufacturer’s instructions.
3. Self Retracting Lifelines (SRL’s) used with this product must have a Maximum Arrest Force (MAF) rating not exceeding 900lbs (4kN).
4. Where required by regulation, each installation **MUST BE** installed under the supervision of a Qualified Person.

5. This equipment **MUST BE** set up and operated under the supervision of a Qualified Person.

GENERAL SPECIFICATIONS

Capacity (Rescue):	Maximum 2 workers weighing not more than 310lbs (141kg) each.
Capacity (Fall Arrest):	1 worker weighing not more than 310lbs (141kg).
Allowable MAF Rating for SRL’s	900lbs (4kN)
Test Number:	TBP-181
Weight:	50 lbs (22.8 kg)

MATERIALS & CONSTRUCTION

General Construction:	Extruded 6061-T6 Aluminum
Brackets / Connectors	Steel / Aluminum
Pulleys & Rollers	Black Acetal
Sleeve Liner/Thrust Bearing Material:	HDPE
Hardware	Grade 5, Grade 8 Zinc-Plated
Finish (aluminum)	- Safety Orange powder coat -Mill Finish
Finish (Steel)	-CS-500 Zinc Plated (Type II Zinc, SC-2, ASTM B633-85)

CERTIFICATION

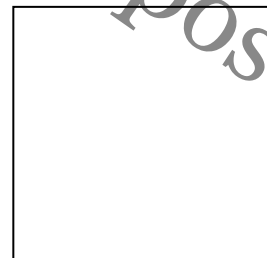

DAVIT DIMENSIONS

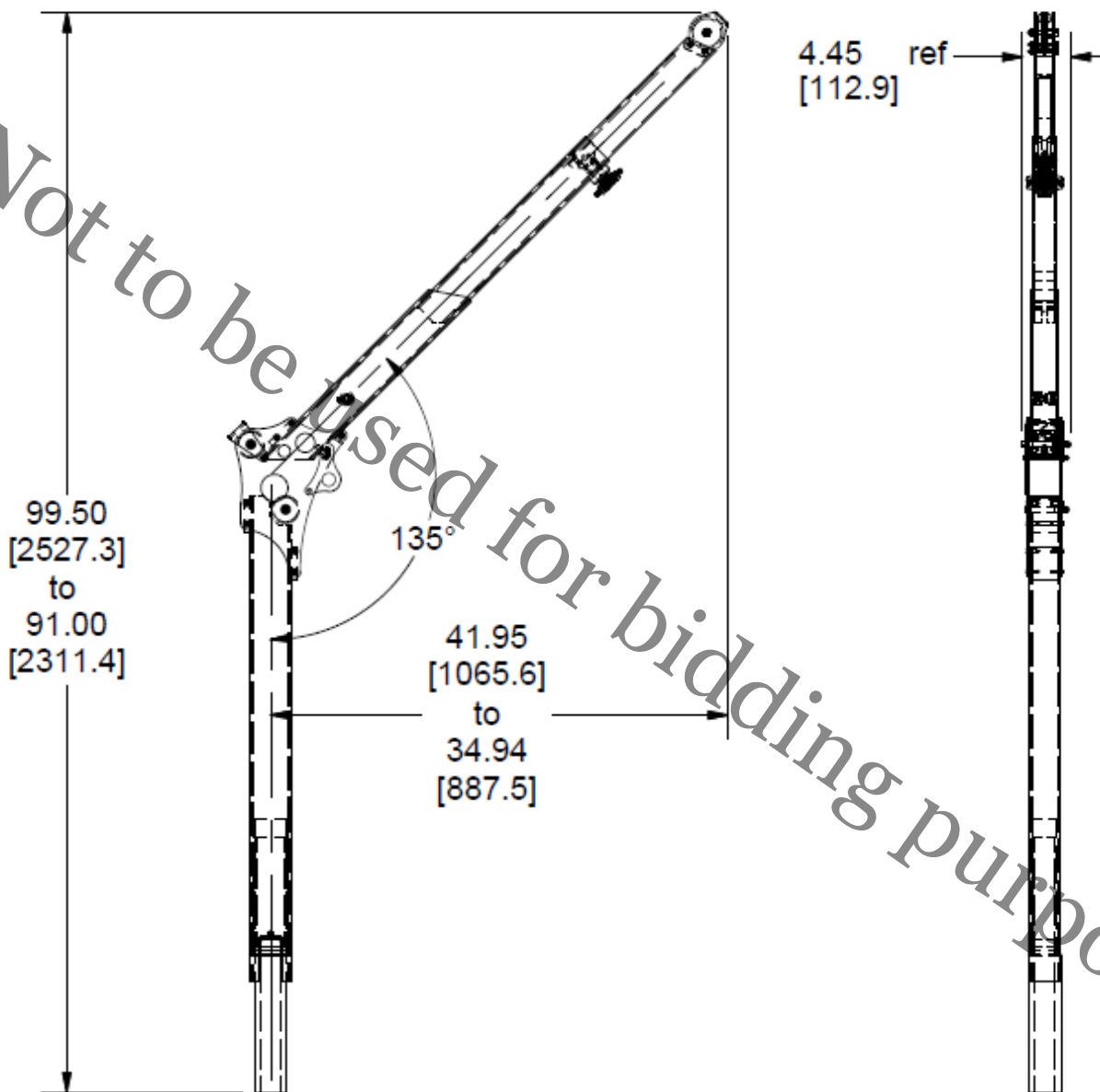

PRODUCT DESCRIPTION

The PRO-Series 4-Point Wall Mount Base is designed to weld or bolt to a wide variety of vertical structures including beams, columns, tanks, walkways and concrete surfaces.

This sleeve is compatible with a variety of common manufacturer’s davits*, including UCL Safety Systems, Miller DuraHoist, Uni Hoist, and many DBI/Sala products.

*Installer must confirm product compatibility and equivalence of mounting requirements.



The PRO-Series Wall Mount Base is available in the following materials and finishes:

Zinc-Plated Mild Steel	Item Number 30032
Hot-Dip Galvanized Mild Steel*	Item Number 30054
304 Stainless Steel*	Item Number 30033
316 Stainless Steel*	Item Number 30053

*Indicates a Special Order Item, Please call for availability.

APPLICATION RESTRICTIONS

1. This product MUST BE used only with accessories designed, manufactured, and/or approved by Tuff Built Products Inc.
2. All system components MUST BE installed, inspected, maintained, and used in accordance with the manufacturer’s instructions.
3. Structures selected for the installation of this sleeve MUST BE capable of supporting a minimum 90,000 in-lb (10,000N.m) moment and 5000 lb (22.2 kN) vertical load, or MUST BE approved by a Qualified Person so as to maintain an appropriate safety factor for the given application(s) as specified in applicable regulations.

4. Fasteners used to mount this sleeve MUST provide an ultimate pull-out strength of at least 11,000 lbs (48.9kN) per fastener, or MUST BE selected and installed under the supervision of a Qualified Person so as to maintain an appropriate safety factor for the given application(s) as specified in applicable regulations.
5. Where required by regulation, each installation MUST BE installed under the supervision of a Qualified Person.
6. This equipment MUST BE set up and operated under the supervision of a Competent Person.

GENERAL SPECIFICATIONS

Capacity: This base is designed to support the rated working load of all standard Tuff Built davits when installed as per manufacturer’s instructions.

Test Number	TB-119
Weight	10.5lbs (4.8 kg)

MATERIALS & CONSTRUCTION

General Construction	Welded Steel/Stainless Steel
Sleeve Liner/Thrust Bearing Material:	High Density Polyethylene
Finish Specification (Zinc)	CS-500 (Type II, SC-2, ASTM B633-85
Finish Specification (Galvanized):	CAN/CSA G 164, ASTM A 123
Finish (Stainless Steel)	Brush Blast

RELEVANT STANDARDS

This product meets the applicable requirements of the following standards when installed and used as per the manufacturer’s instructions:

- EN 795
- OSHA 1910.146, and 1926.502
- ANSI/ASSE Z117.1, ANSI/ASSE Z359

CERTIFICATION



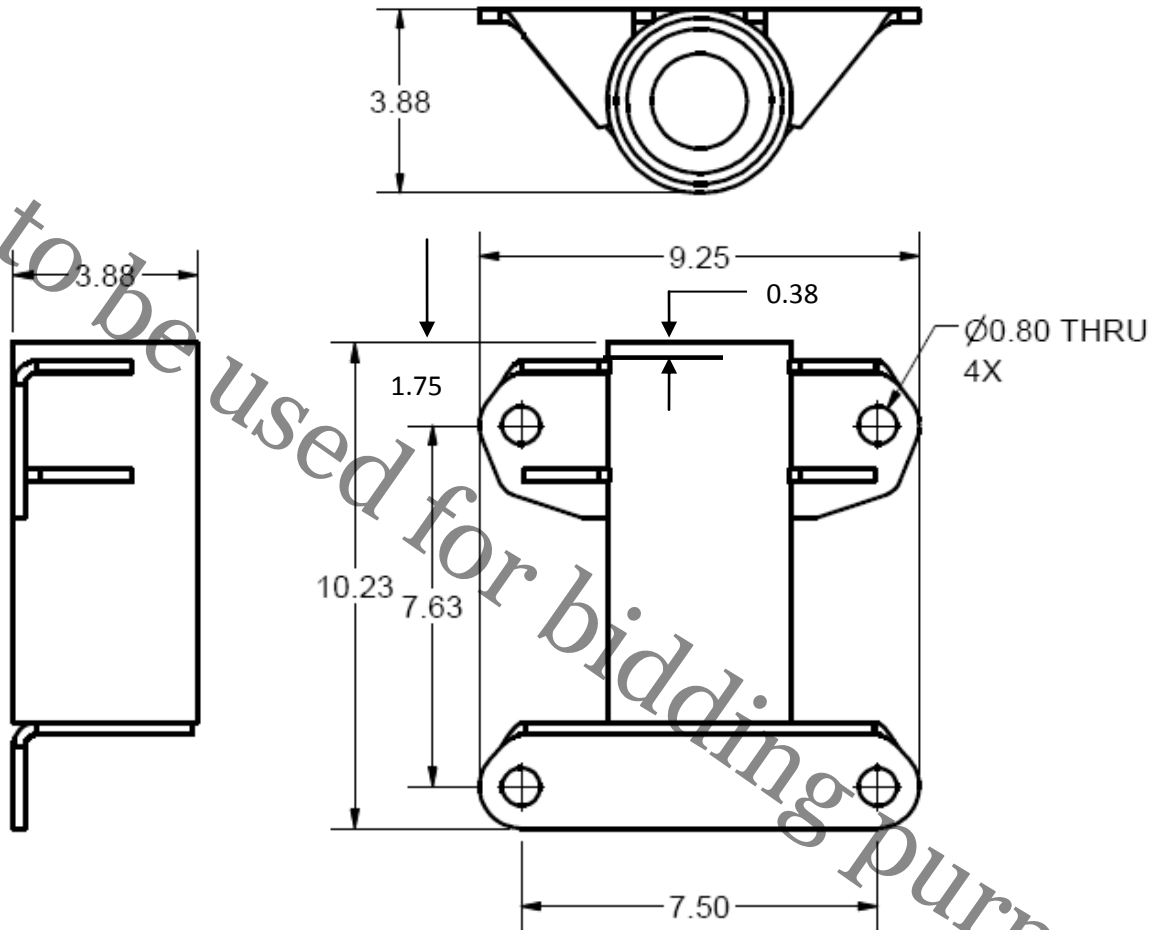

Not to be used for bidding purposes

Section IV

General Provisions & Technical Specifications for Sanitary Sewer Construction

(Separate document incorporated by reference)